

FUJIFILM

DIGITAL CAMERA
FinePix S3000



Exif Print

xD
xD-Picture Card™



digital
Tools for the imagination.

Getting Ready **1**

Basic Photography **2**

Advanced Features
Photography **3**

Advanced Features
Playback **4**

Settings **5**

Software Installation **6**

Viewing Images **7**

OWNER'S MANUAL

This manual will show you how to use your FUJIFILM DIGITAL CAMERA FinePix S3000 correctly. Please follow the instructions carefully.

BL00332-200 (1) **E**

Warning

To prevent fire or shock hazard, do not expose the unit to rain or moisture.

For customers in the U.S.A.

*Tested To Comply
With FCC Standards
FOR HOME OR OFFICE USE*

FCC Statement

This device complies with part 15 of the FCC Rules. Operation is subject to the following two conditions: (1) This device may not cause harmful interference, and (2) this device must accept any interference received, including interference that may cause undesired operation.

CAUTION

This equipment has been tested and found to comply with the limits for a Class B digital device, pursuant to Part 15 of the FCC Rules. These limits are designed to provide reasonable protection against harmful interference in a residential installation. This equipment generates, uses, and can radiate radio frequency energy and, if not installed and used in accordance with the instructions, may cause harmful interference to radio communications. However, there is no guarantee that interference will not occur in a particular installation. If this equipment does cause harmful interference to radio or television reception, which can be determined by turning the equipment off and on, the user is encouraged to try to correct the interference by one or more of the following measures:

- Reorient or relocate the receiving antenna.
- Increase the separation between the equipment and receiver.
- Connect the equipment into an outlet on a circuit different from that to which the receiver is connected.

— Consult the dealer or an experienced radio/TV technician for help.

You are cautioned that any changes or modifications not expressly approved in this manual could void the user's authority to operate the equipment.

Notes on the Grant:

To comply with Part 15 of the FCC rules, this product must be used with a Fujifilm-specified ferrite-core USB cable and DC supply cord.

For customers in Canada

CAUTION

This Class B digital apparatus complies with Canadian ICES-003.

**Please read the Safety Notes (⇒P.126)
and make sure you understand them
before using the camera.**

Contents

Warning	2
Preface	6
Accessories included	7
Nomenclature	8

1 Getting Ready

PREFACE	11
Attach the lens cap, strap and adapter ring	11
Attaching the Lens Cap	12
LOADING THE BATTERY AND xD-Picture Card™	14
SWITCHING ON AND OFF/ SETTING THE DATE AND TIME	17
CORRECTING THE DATE AND TIME	18
CHANGING THE DATE ORDER	20
CHECKING THE REMAINING BATTERIES CHARGE	20
SELECTING THE LANGUAGE	21

2 Basic Photography

TAKING PICTURES (AUTO MODE)	22
■ Indicator Lamp Display	27
Number of available frames	28
USING AF/AE LOCK	29
FRAMING GUIDELINE FUNCTION	31
DIGITAL ZOOM	32
⚡ FLASH	33
Auto Flash Mode (no icon)	34
👁 Red-Eye Reduction	34

⚡ Forced Flash	35
⚡ Slow Synchro	35
👁 Red-Eye Reduction + Slow Synchro	35
Suppressed Flash	36
📎 MACRO (CLOSE-UP) PHOTOGRAPHY	37

▶ PLAYBACK

VIEWING YOUR IMAGES (PLAYBACK)	38
Fast Forwarding Images	38
MULTI-FRAME PLAYBACK	39
PLAYBACK ZOOM	40
ERASING SINGLE FRAME	41

3 Advanced Features Photography

ADVANCED FEATURES PHOTOGRAPHY	43
■ Photography Mode Specifications	43

📷 STILL IMAGE

AUTO AUTO	44
📷 MANUAL	44
📍 SCENE POSITION	45

📹 MOVIE

📹 MOVIE (VIDEO)	47
PHOTOGRAPHY MENU OPERATION	50

PHOTOGRAPHY MENU

⏪ SETTING QUALITY MODE (NUMBER OF RECORDED PIXELS FOR IMAGES)	51
🕒 SELF-TIMER PHOTOGRAPHY	53
☑ EV (EXPOSURE COMPENSATION)	55
WB WHITE BALANCE (SELECTING THE LIGHT SOURCE)	56

⚡ FLASH (FLASH BRIGHTNESS ADJUSTMENT)	57
📷 SHARPNESS	57
📷 APERTURE-PRIORITY AUTO	58

4 Advanced Features Playback

PLAYING BACK MOVIES (VIDEO)	59
-----------------------------------	----

▶ PLAYBACK MENU

🗑 ERASING SINGLE/ALL FRAMES	61
🔒 PROTECTING IMAGES:FRAME/SET ALL/RESET ALL	65
📷 HOW TO SPECIFY PRINT OPTIONS (DPOF)	70
📷 DPOF SET FRAME (FRAME SET/RESET)	71
📷 DPOF SET FRAME (RESET ALL)	74

5 Settings

📷 LCD BRIGHTNESS	76
📷 USING SET-UP	77
■ SET-UP Menu Options	78

SET-UP

POWER SAVE	79
FORMAT	80

6 Software Installation

6.1 THE SOFTWARE COMPONENTS	81
6.2 INSTALLATION ON A Windows PC	82
6.3 INSTALLATION ON A Mac OS 9.0 TO 9.2	85
6.4 INSTALLATION ON A Mac OS X	90

7 Viewing Images

7.1 CAMERA CONNECTION	95
7.1.1 Using the AC power adapter (sold separately)	95
7.1.2 Connecting to a TV	96
7.1.3 Connecting to a computer	97
7.1.4 Disconnecting the camera	102
7.2 USING FinePixViewer	104
7.2.1 Mastering FinePixViewer	104
7.2.2 Uninstalling the software	105

System Expansion Options	108
Accessories Guide	109
Notes on Using Your Camera Correctly	111
Notes on the Power Supply	112
Applicable Batteries	112
Notes on the Batteries	112
Notes on Using the AC Power Adapter	114
Notes on the xD-Picture Card™	115
Warning Displays	117
Troubleshooting	120
Specifications	123
Explanation of Terms	125
Safety Notes	126
EC Declaration of Conformity	129
IMPORTANT	130

Preface

■ Test Shots Prior to Photography

For particularly important photographs (such as weddings and overseas trips), always take a test photograph and view the image to make sure that the camera is functioning normally.

- Fuji Photo Film Co., Ltd. cannot accept liability for any incidental losses (such as the costs of photography or the loss of income from photography) incurred as a result of faults with this product.

■ Notes on Copyright

Images recorded using your digital camera system cannot be used in ways that infringe copyright laws without the consent of the owner, unless intended only for personal use. Note that some restrictions apply to the photographing of stage performances, entertainments and exhibits, even when intended purely for personal use. Users are also asked to note that the transfer of **xD-Picture Card** containing images or data protected under copyright laws is only permissible within the restrictions imposed by those copyright laws.

■ Liquid Crystal

If the LCD monitor is damaged, take particular care with the liquid crystal in the monitor. If any of the following situations arise, take the urgent action indicated.

- If liquid crystal comes in contact with your skin
Wipe the area with a cloth and then wash thoroughly with soap and running water.
- If liquid crystal gets into your eye
Flush the affected eye with clean water for at least 15 minutes and then seek medical assistance.
- If liquid crystal is swallowed
Flush your mouth thoroughly with water. Drink large quantities of water and induce vomiting. Then seek medical assistance.

■ Notes on Electrical Interference

If the camera is to be used in hospitals or aircrafts, please note that this camera may cause interference to other equipment in the hospital or aircraft. For details, please check with the applicable regulations.

■ Handling Your Digital Camera

This camera contains precision electronic components. To ensure that images are recorded correctly, do not subject the camera to impact or shock while an image is being recorded.

■ Trademark Information

-  and **xD-Picture Card™** are trademarks of Fuji Photo Film Co., Ltd.
- IBM PC/AT is a registered trademark of International Business Machines Corp. of the U.S.A.
- Macintosh, Power Macintosh, iMac, PowerBook, iBook and Mac OS are trademarks of Apple Computer, Inc., registered in the U.S. and other countries.
- Adobe Acrobat® Reader® is a trademark of Adobe Systems Incorporated of the U.S.
- Microsoft, Windows, and the Windows logo are trademarks, or registered trademarks of Microsoft Corporation in the United States and/or other countries. Windows is an abbreviated term referring to the Microsoft® Windows® Operating System.
- * The "Designed for Microsoft® Windows® XP" logo refers to the camera and the driver only.
- Other company or product names are trademarks or registered trademarks of the respective companies.

■ Explanation of Color Television System

NTSC: National Television System Committee, color television telecasting specifications adopted mainly in the U.S.A., Canada and Japan.

PAL: Phase Alternation by Line, a color television system adopted mainly by European countries and China.

■ Exif Print (Exif ver. 2.2)

Exif Print Format is a newly revised digital camera file format that contains a variety of shooting information for optimal printing.

Accessories included

● 16MB, xD-Picture Card™ (1)

Supplied with: Anti-static case (1)



● Adapter Ring (1)

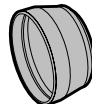

● Strap (1)



● USB Interface Set (1)

- CD-ROM: Software for FinePix SX (1)
- USB cable with Noise Suppression core (1)
- Quick start guide for Camera and Software installation (1)

● LR6 AA-size alkaline batteries (4)

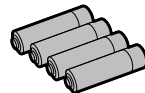

● Lens Cap (1)



● Video cable (1) (plug (2.5 mm dia.) to pin-plug) Approx. 1.5 m



● Owner's Manual (this manual) (1)

Nomenclature

* Refer to the pages in parentheses for information on using the camera features.

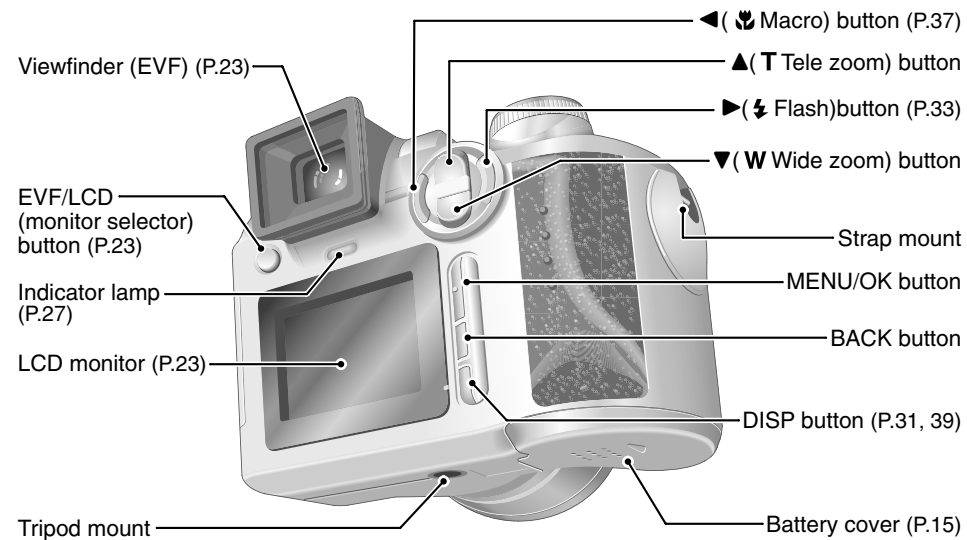
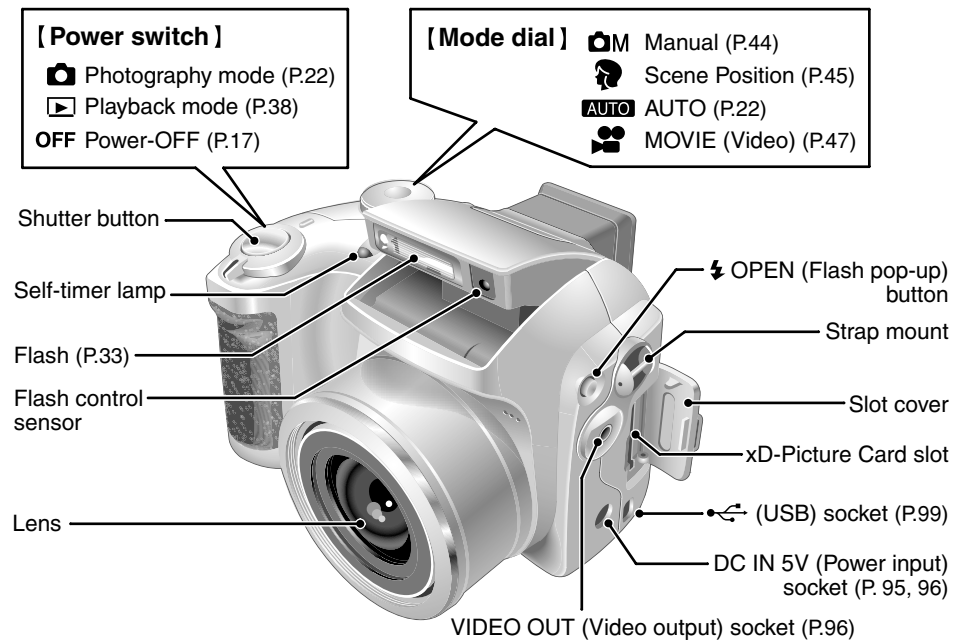

Nomenclature (Sample display)

■ Still photography mode

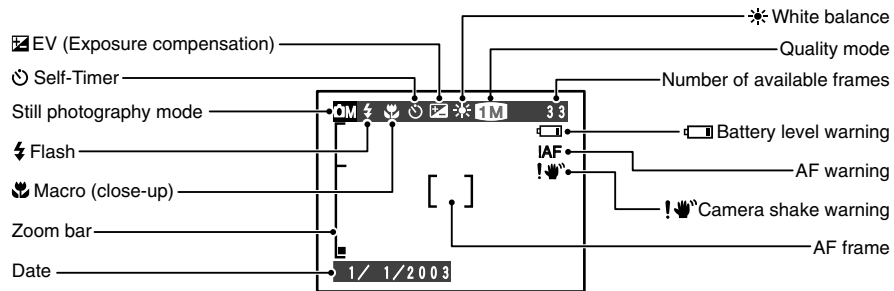

■ Playback mode

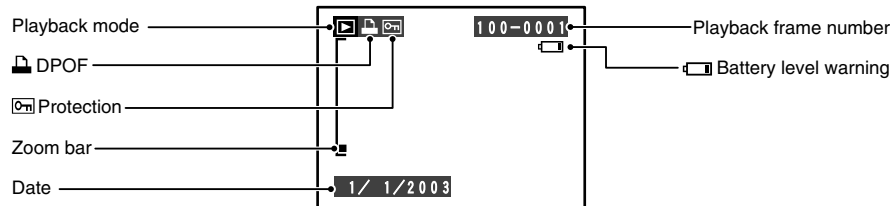

Attach the lens cap, strap and adapter ring

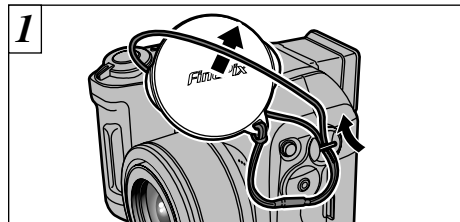

Pull the lens cap cord through the strap mount.

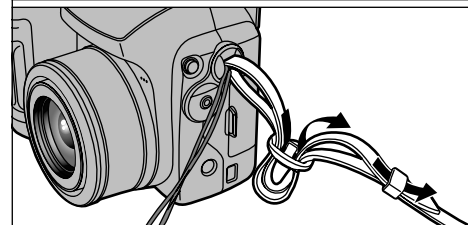
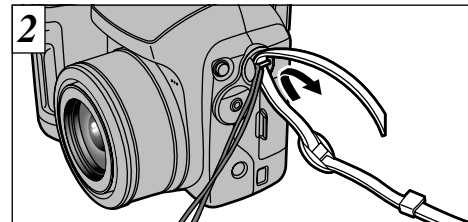

Attach the strap to the strap mounts on the camera. Once you have attached both ends of the strap, check carefully to ensure that the strap is firmly secured.

⚠ Failure to attach the strap correctly can result in the camera being dropped.

⚠ Attach the lens cap cord to avoid losing the lens cap.

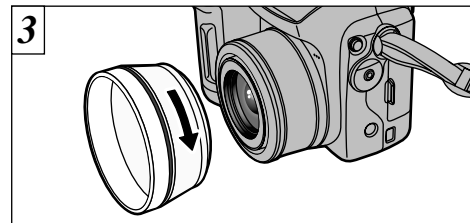

Screw the adapter ring in the direction of the arrow to mount it on the camera.

Mounting the adapter ring on the camera protects the lens and allows you to attach the optional conversion lens. The adapter ring should be mounted on the camera at all times to protect the lens.

Attaching the Lens Cap

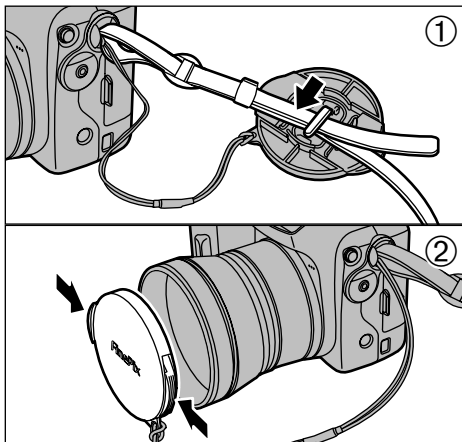

- ① To prevent the lens cap from appearing in the shot when you take pictures, attach the lens cap to the strap.
- ② Fit and remove the lens cap by squeezing the left and right sides of the cap.

◆ Overview of the conversion lens ◆

Wide conversion lens WL-FX9/WL-FX9B

Changes the focal length by a factor of 0.79× (wide-angle: equivalent to 30 mm) without altering the F-stop value of the lens.

● Wide conversion lens specifications

Magnification : 0.79×
 Lens configuration : 3 lenses in 3 groups
 Dimensions : 32 mm (1.26 in.) × 70 mm (2.76 in.) dia.
 Mass (Weight) : Approx. 185 g (6.5 oz.)
 Accessories : Adapter Ring AR-FX9, Lens caps (front and rear), Lens pouch

- ⚠ Only use the wide conversion lens at the wide-angle zoom setting.
- ⚠ The wide conversion lens and built-in flash cannot be used together.

- ⚠ The adapter ring enclosed with the FinePix S3000(AR-FX3) should be used with these conversion lenses. The adapter rings provided with these conversion lenses (AR-FX9 for FinePix 4900 zoom/6900 zoom/S602 zoom/S7000) cannot be used with the FinePix S3000.

- ⚠ Commercially available filters can be mounted on the lens when the adapter ring is attached, but no more than one filter should be mounted at a time.

Teleconversion lens TL-FX9/TL-FX9B

Changes the focal length by a factor of 1.5× (telephoto: equivalent to 340 mm) without altering the F-stop value of the lens.

● Teleconversion lens specifications

Magnification : 1.5×
 Lens configuration : 3 lenses in 3 groups
 Dimensions : 55 mm (2.17 in.) × 65 mm (2.56 in.) dia.
 Mass (Weight) : Approx. 100 g (3.5 oz.)
 Accessories : Adapter Ring AR-FX9, Lens caps (front and rear), Lens pouch

- ⚠ The TL-FX9/TL-FX9B should only be used for telephoto shots where eclipsing does not occur. Eclipsing occurs at wide-angle settings.
- ⚠ The built-in flash cannot be used with the teleconversion lens.

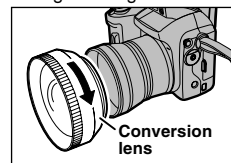

LOADING THE BATTERY AND xD-Picture Card™

Compatible batteries

- AA-size alkaline batteries (4) or AA-size Ni-MH rechargeable batteries (4) (sold separately).

⚠ Please use the same brand and grade AA-size alkaline batteries as those supplied with the camera.

◆ How to use the batteries ◆

- Never use the following types of batteries, as this could cause serious problems such as battery fluid leakage or overheating:

1. Batteries with split or peeling outer casings
2. Combinations of different types of batteries or new and used batteries together

Outer casing

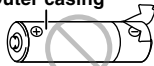

- Do not use manganese or Ni-Cd batteries.

- Soil, such as fingermarks on the poles of the batteries can significantly reduce the amount of time for which the batteries can be used.

- The time for which AA-size alkaline batteries (referred to hereafter simply as alkaline batteries) can be used varies depending on the brand, and some alkaline batteries may stop providing power more quickly than those supplied with the camera. Note also that due to their nature, the time for which alkaline batteries can be used decreases in cold conditions (0°C to +10°C/+32°F to +50°F). The use of AA-size Ni-MH batteries is recommended for this reason.

- Use the optional charger to charge AA-size Ni-MH batteries.

- See P.112-114 for other notes on using batteries.

- When first purchased or if left unused for a long period, the time for which AA-size Ni-MH batteries can be used may be shorter. See P.113-114 for details.

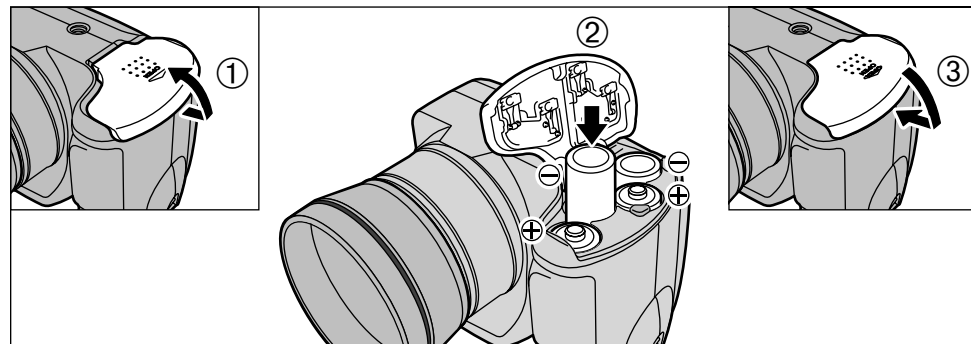

- ① Slide the battery cover out and lift it open.
- ② Insert the batteries correctly as indicated by the polarity icons.
- ③ Close the battery cover.

⚠ Do not apply excessive force to the battery cover.

Do not open the battery cover while the camera is still switched on as this could corrupt the image files on the **xD-Picture Card** or damage the **xD-Picture Card** itself.

◆ Replacing the batteries ◆

Check that the Power switch is set to "OFF", open the battery cover and remove the batteries.



⚠ Take care not to drop the batteries when you open or close the battery cover.

LOADING THE BATTERY AND xD-Picture Card™

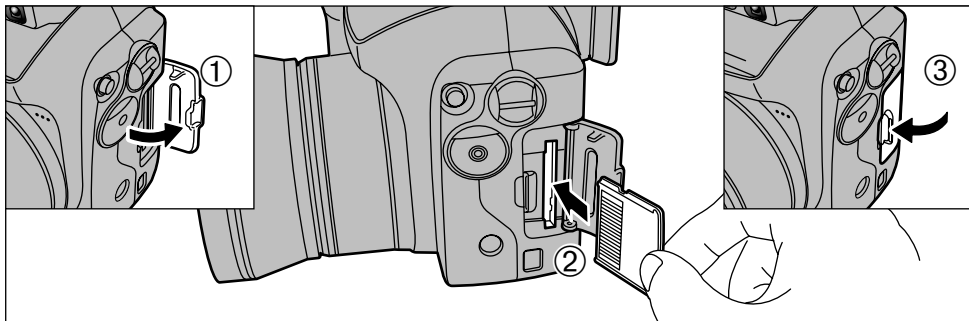

- ① Open the slot cover.
- ② Firmly push the **xD-Picture Card** fully into the xD-Picture Card slot.
- ③ Close the slot cover.

- ⚠ Opening the slot cover while the camera is still switched on, the camera is switched off.
- ⚠ The **xD-Picture Card** will not slide fully into the slot if it is inserted facing the wrong way. Be careful not to apply excessive force to the **xD-Picture Card**.

◆ Replacing the xD-Picture Card ◆

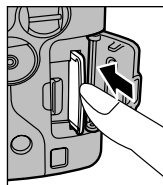

When you push the **xD-Picture Card** into the slot and then slowly remove your finger, the lock is released and the **xD-Picture Card** is pushed out. You can then pull the **xD-Picture Card** the rest of the way out.

- ⚠ Take care not to remove your finger too quickly after the lock is released, as the card may spring completely out of the slot.

SWITCHING ON AND OFF/SETTING THE DATE AND TIME

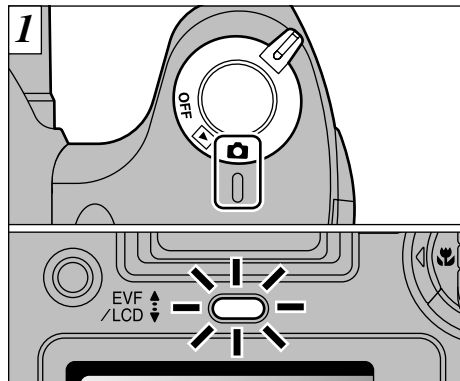

Set the Power switch to turn the camera on and off.

- 📷 : Photography mode
- ▶ : Playback mode
- OFF: Power-OFF

When you switch the camera on, the indicator lamp lights (green).

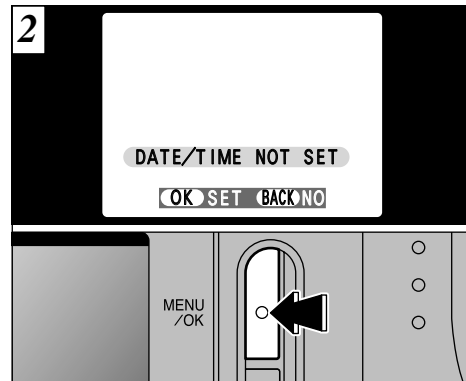

When you first switch the camera on, the date is cleared. Press the "MENU/OK" button to set the date and time.

- ⚠ If a confirmation message does not appear, refer to "CORRECTING THE DATE AND TIME" (→P.18) to check and correct the date and time.
- ⚠ When also leaving the camera for a long period with the batteries removed, this confirmation message will appear.
- ⚠ To set the date and time later, press the "BACK" button.
- ⚠ If you do not set the date and time, this confirmation message will appear each time you switch the camera on.

CORRECTING THE DATE AND TIME

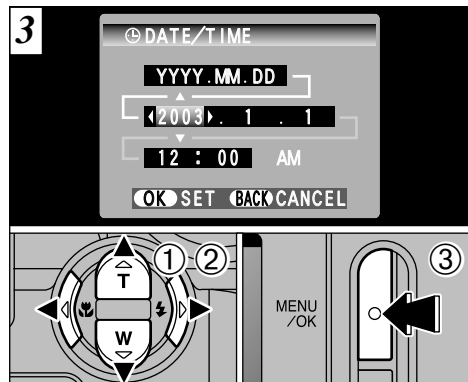

- ① Use “◀” and “▶” to select Year, Month, Day, Hour or Minute.
- ② Press “▲” or “▼” to correct the setting.
- ③ Once you have set the date and time, press the “MENU/OK” button. Pressing the “MENU/OK” button switches the camera to Photography or Playback mode.

- ⚠ If you hold down “▲” or “▼”, the numbers change continuously.
- ⚠ When the time displayed passes “12:00”, the AM/PM setting automatically switches.

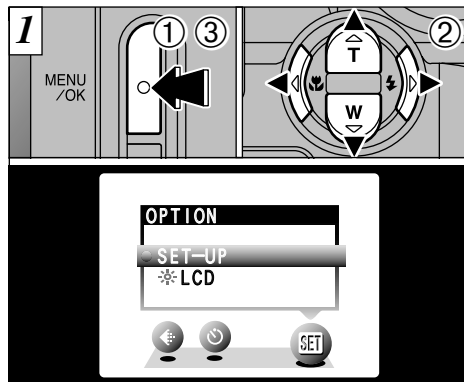

- ① Press the “MENU/OK” button.
- ② Press “◀” or “▶” to select “OPTION” and then use “▲” or “▼” to select “SET-UP”.
- ③ Press the “MENU/OK” button.

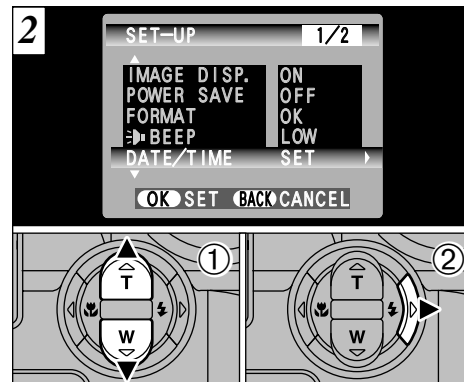

- ① Press “▲” or “▼” to select “DATE/TIME”.
- ② Press “▶”.

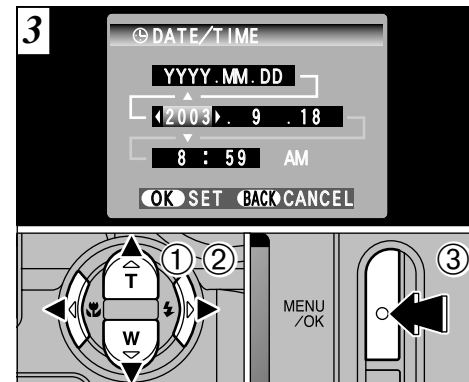

- ① Press “◀” or “▶” to select Year, Month, Day, Hour or Minute.
- ② Press “▲” or “▼” to correct the setting.
- ③ Always press the “MENU/OK” button after the settings are completed.

- ⚠ Holding down “▲” or “▼”, the numbers change continuously.
- ⚠ When the time displayed passes “12:00”, the AM/PM setting automatically switches.

CHANGING THE DATE ORDER

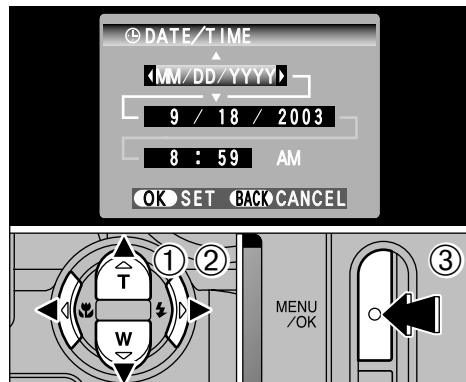

- 1 Press “◀” or “▶” to select the date order.
- 2 Press “▲” or “▼” to set the date order. Refer to the table below for details of the settings.
- 3 Always press the “MENU/OK” button after the settings are completed.

Date order	Explanation
YYYY.MM.DD	Displays the date in the “year.month. day” format.
MM/DD/YYYY	Displays the date in the “month/day/ year” format.
DD.MM.YYYY	Displays the date in the “day.month. year” format.

CHECKING THE REMAINING BATTERIES CHARGE

Switch the camera on and check that no battery level warning (🔋 or 🔋) is displayed on the LCD monitor. If no icon is displayed, there is ample charge left in the batteries.

- 🔋 **Lit red:**
Batteries charge low. Replace or recharge the batteries as they will run out shortly.
 - 🔋 **Blinking red:**
The batteries are exhausted. The display will shortly go blank and the camera will stop working. Replace or recharge the batteries.
- ⚠ Do not reuse batteries that have no remaining charge (🔋 blinking red) as this can result in faults such as the camera switching off without retracting the lens.
- ⚠ The above estimates are for the Still image modes. In Playback mode, the transition from “🔋” to “🔋” may take less time.

◆ Power Save Function ◆

If the camera is not used for 2 minutes, this function automatically switches it off. When this function is enabled, the screen switches off to conserve battery power if the camera is not used in any way for 30 seconds (See P.79 for details). To switch the camera back on, turn the Power switch to “OFF” briefly and then back to “📷”.

SELECTING THE LANGUAGE

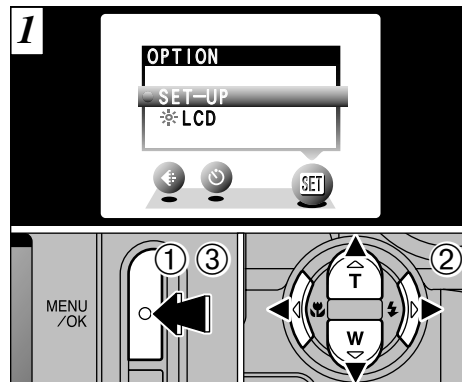

- 1 Press the “MENU/OK” button.
- 2 Press “▶” or “▶” to select “OPTION” and then press “▲” or “▼” to select “SET-UP”.
- 3 Press the “MENU/OK” button.

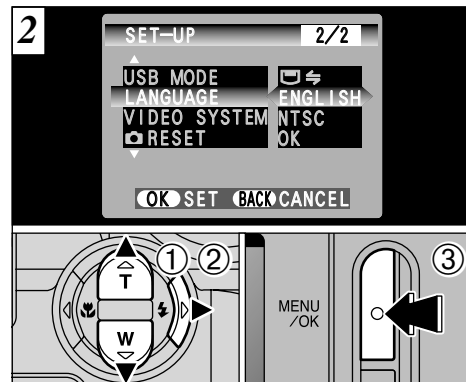

- 1 Press “▲” or “▼” to select “LANGUAGE”.
- 2 Press “▶” to select “ENGLISH”, “FRANCAIS”, “DEUTSCH”, “ESPAÑOL” or “中文”. You can cycle through the language settings by pressing “▶”.
- 3 Press the “MENU/OK” button.

- ⚠ The screens in this manual are shown in English.
- ⚠ See P.78 for more information on the “OPTION” menu.

You've read the chapter on getting ready and the camera is now set up and ready to take pictures. The Basic Photography section explains the three basic steps of "taking pictures", "viewing pictures" and "erasing pictures". Master the basic steps by actually trying them out on the camera as you go.

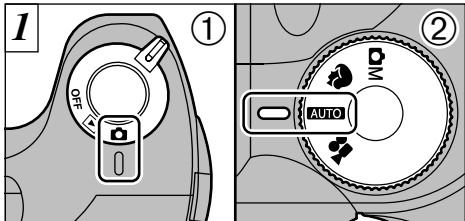
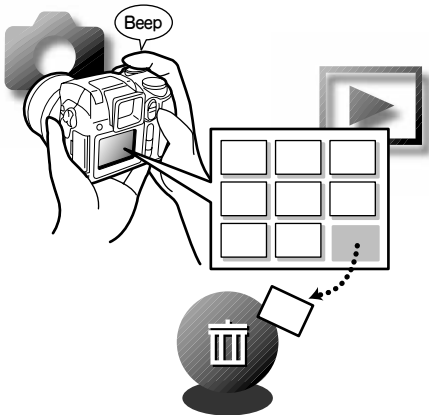

① Set the Power switch to "📷" ② and set the Mode dial to "AUTO".

- **Effective Photography Range**
Approx. 80 cm (2.6 ft.) to infinity

- ⚠ If the subject is closer than approximately 80 cm (2.6 ft.), set the camera to Macro mode (→P.37).
- ⚠ If a "CARD ERROR", "WRITE ERROR", "READ ERROR" or "CARD NOT INITIALIZED" message appears, see P.117, 118.

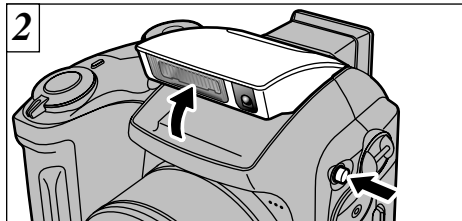

Press the "⚡ OPEN" button to make the flash pop up.

- ⚠ If the photography mode is "AUTO", use the Auto Flash mode.
- ⚠ When the flash is popped up or you are using the flash to take pictures, you may see the image disappear and the screen go dark as the flash charges. The indicator lamp blinks orange while the flash is charging.
- ⚠ If you use the flash in very dusty environments or when it is snowing, the flash may reflect off snowflakes or floating dust particles so that they appear as glowing white dots on your image.

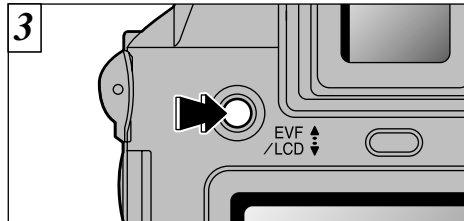

Immediately after you select Photography mode, the viewfinder (EVF) switches on. You can choose whether to use the viewfinder (EVF) or the LCD monitor to take pictures by pressing the "EVF/LCD" button to switch between the two.

- ⚠ You can specify individually whether the viewfinder (EVF) or the LCD monitor is used in the Photography and Playback modes.

Mode	Default setting	After switching
📷 Photography mode	EVF	LCD monitor
▶ Playback mode	LCD monitor	EVF

* The selection reverts to the default setting when you switch the camera off.

TAKING PICTURES (AUTO MODE)

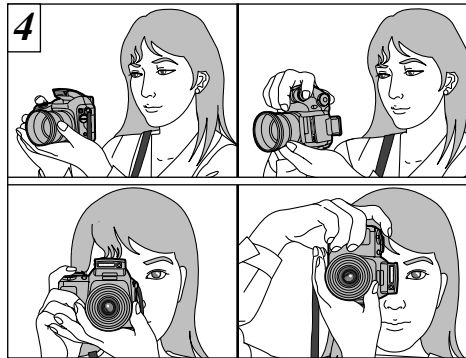

Loop the strap over your wrist, brace your elbows firmly against your body and hold the camera with both hands. Be careful to ensure that the lens and flash control sensor are not obscured by your hands or the camera strap.

- ⚠ The image will be blurred if the camera moves when taking the picture (camera shake). Use a tripod to avoid camera shake, particularly for shots in dark locations when the flash is set to Suppressed Flash mode.
- ⚠ There may be some unevenness in the brightness at the lower edge of the LCD monitor. This is normal and does not indicate a fault. This does not affect the photographed image.

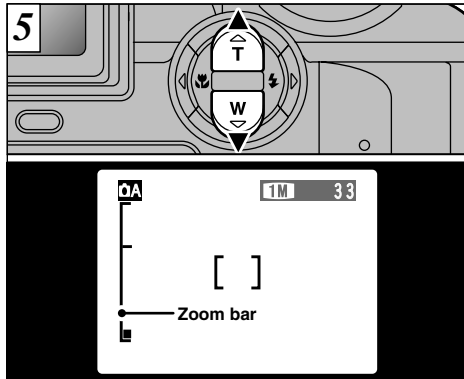

To zoom in on the subject, press “▲” (T TELE Zoom). To zoom out, press “▼” (W WIDE Zoom). A “zoom bar” appears on the screen when you zoom in or out.

- **Optical zoom focal length (35mm camera equivalent)**
Approx. 38 mm-228 mm
Maximum zoom scale: 6×
- ⚠ Zooming pauses briefly when it switches between optical zoom and digital zoom (⇒P.32). Press the same zoom button again to switch zoom modes.



Frame the shot so that the subject fills the entire AF (Auto Focus) frame.

- ⚠ The image shown on the screen before taking the shot may differ in its brightness, color, etc. from the image actually recorded. If necessary, play back the recorded image to check it (⇒P.38).
- ⚠ In some conditions it may be difficult to see your subject clearly on the LCD monitor (Such as in sunny weather outdoors). In such situations, use the viewfinder (EVF) to take the shot.
- ⚠ If the subject is not in the AF frame, use AE/AF lock to take the picture (⇒P.29).

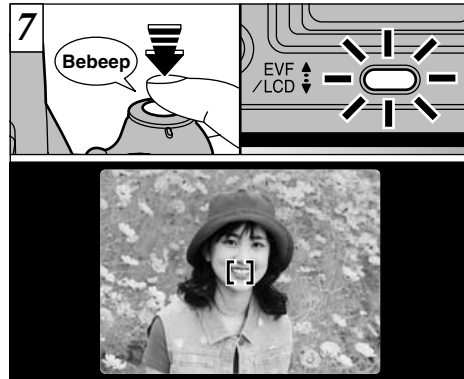

When you press the Shutter button down halfway, the camera emits a short double-beep and focuses on your subject (the indicator lamp (green) changes from blinking to steady). At that point, the AF frame on the screen becomes smaller and the camera sets the shutter speed and aperture.

- ⚠ If the camera does not emit a short double-beep and “!AF” appears on the screen, the camera cannot focus.
- ⚠ When you press the Shutter button down halfway, the image on the screen freezes temporarily. However, this image is not the recorded image.
- ⚠ If “!AF” is displayed on the screen (e.g. the shot is too dark for the camera to focus), try standing about 2 m (6.6 ft.) from your subject to take the picture.

TAKING PICTURES (AUTO MODE)

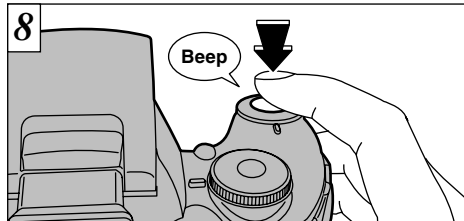

To take the picture, press the shutter button down fully without lifting your finger off it. The camera beeps and takes the picture, and the data is then recorded.

- ⚠ There is a slight delay between the Shutter button being pressed and the shot being taken. If necessary, playback the shot to check the image.
 - ⚠ If you press the Shutter button down fully in one motion, the shot is taken without the AF frame changing.
 - ⚠ When you take a picture, the indicator lamp lights orange (not ready to shoot) before switching back to green to indicate that the camera is again ready for shooting.
 - ⚠ The Indicator lamp blinks orange while the flash is charging. The screen may go dark briefly. This is normal and does not indicate a fault.
- 26 ⚠ See P.117-119 for information on the warning displays.

◆ Warnings displayed when the Shutter button is pressed down halfway ◆

! AF Shot not focused.

Solution

- Move at least 2 m (6.6 ft.) away from the subject before taking the shot.
- Use AF/AE lock to take the shot (⇒P.29).

! Hand Strong likelihood of camera shake due to the slow shutter speed.

Solution

- Use the flash.
- Use a tripod.

■ Indicator Lamp Display

Display	Status
Lit green	Ready to shoot.
Blinking green	AF/AE operating or camera shake/AF warning (ready to shoot)
Blinking green and orange alternately	Recording data to the xD-Picture Card (ready to shoot).
Lit orange	Recording data to the xD-Picture Card (not ready to shoot)
Blinking orange	Charging the flash (flash will not fire)
Blinking green (1-second intervals)	Camera in Power Save mode (⇒P.79)
Blinking red	<ul style="list-style-type: none">• xD-Picture Card-related warning The xD-Picture Card is not loaded, is not formatted, is incorrectly formatted or is fully recorded. xD-Picture Card fault.• Lens operation error.

◆ Subjects not suitable for autofocus ◆

Though the FinePix S3000 uses an accurate autofocus mechanism, it may have difficulty focusing or not be able to focus at all for the types of subject and situation listed below. In such cases, the image may be out of focus.

- Very shiny subjects such as a mirror or car body.
 - Subjects photographed through glass.
 - Subjects that do not reflect well, such as hair or fur.
 - Subjects with no substance, such as smoke or flames.
 - When the subject is dark.
 - When there is very little contrast between the subject and the background (such as white walls or subjects dressed in the same color as the background).
 - Subjects moving at high speed.
 - When something other than your subject is close to the AF frame, has contrasting areas of light and dark and is either closer or further away than your subject (as when you photograph someone against a background with strongly contrasting elements).
- For subjects of this type, use AF/AE lock (⇒P.29).

TAKING PICTURES (AUTO MODE)

Number of available frames

The number of available shots is displayed on the screen.

- See P.51 for information on changing the File size.
- At shipment, the default "QUALITY" settings is "1M".



Standard number of frames per xD-Picture Card

The table below shows the standard number of available frames for a new xD-Picture Card formatted on the camera. The larger the xD-Picture Card capacity, the greater the divergence between the actual number of available frames and the number shown here. Also, because the amount of data recorded for a shot varies depending on the subject, in some cases the number of shots may decrease by 2 or may remain the same. As a result, the actual number of recordable shots may either decrease or increase.

Quality mode	3M 3M	2M 2M	1M 1M	0.3M 0.3M
Number of recorded pixels	2048 × 1536	1600 × 1200	1280 × 960	640 × 480
DPC-16 (16 MB)	19	25	33	122
DPC-32 (32 MB)	40	50	68	247
DPC-64 (64 MB)	81	101	137	497
DPC-128 (128 MB)	162	204	275	997
DPC-256 (256 MB)	325	409	550	1997
DPC-512 (512 MB)	651	818	1101	3993

USING AF/AE LOCK

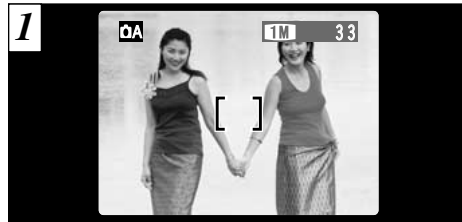

In a shot with this type of composition, the subjects (two people in this case) are not in the AF frame. If the shot is taken at this point, the subjects will not be in focus.



Move the camera slightly so that one of the subjects is in the AF frame.

◆ AF/AE Lock ◆

On the FinePix S3000, when you press the Shutter button down half way, the focus and exposure settings are fixed (AF/AE lock). If you want to focus on a subject that is off to one side of the image or if you want to set the exposure before you compose the final shot, lock the AF and AE settings and then compose and shoot your picture to get the best results.

USING AF/AE LOCK



Pressing the Shutter button down halfway, the camera emits a short double-beep and focuses on the subject. At that point, the AF frame on the screen becomes smaller and the camera sets the shutter speed and aperture (the indicator lamp (green) changes from blinking to lit).



Continue to hold the Shutter button down halfway (AF/AE lock). Move the camera back to the original image and then fully press down on the shutter button.

- ⚠ You can reapply the AF/AE lock as many times as you like before releasing the shutter.
- ⚠ The AF/AE lock operates in all photography modes and can be used to ensure excellent results.

FRAMING GUIDELINE FUNCTION

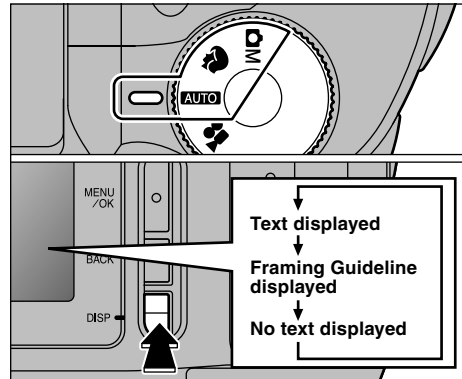

You can use the framing guidelines to take pictures in the "AUTO", "M", "A", and "S" mode. The screen display changes each time you press the "DISP" button. Press the "DISP" button until "Framing Guideline" appears.

◆ Important ◆

Always use the AF/AE lock to compose your picture. Failing to use the AF/AE lock may result in the image being out of focus.

Scene

Use this frame when you want to position your main subject in the center of the frame or when you want to align your shot with the horizon. This feature provides a clear guide to the subject size and the overall balance of the shot so that you get exactly the shot you want.

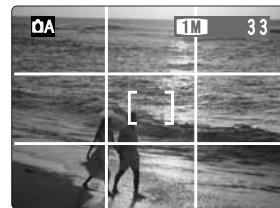

- ⚠ The framing guideline is not recorded on the image.
- ⚠ The lines in the scene frame roughly divide the recorded pixels into three equal parts horizontally and vertically. When the image is printed, the resulting print may be shifted slightly from the scene frame.

DIGITAL ZOOM

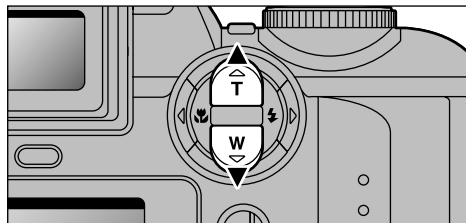

Press “▲” to zoom in on your subject and “▼” to zoom out. When the limit of optical zooming is reached, the digital zoom can then be used to zoom still further.

	Digital zoom focal distance (35 mm camera equivalent)	Max. Zoom Scale
3M	—	
2M	Equivalent to approx. 228 mm-291 mm	1.28×
1M	Equivalent to approx. 228 mm-364 mm	1.6×
0.3M	Equivalent to approx. 228 mm-730 mm	3.2×

- ⚠ The digital zoom cannot be used with the “**3M**” setting.
- ⚠ See P.51 for information on changing the quality mode setting.

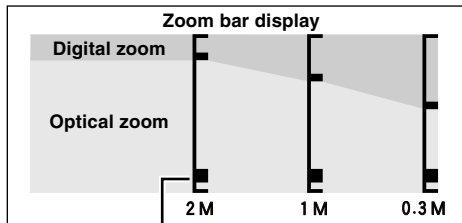

The position of the “■” on the zoom bar indicates the current zoom setting.

- If the “■” is above the dividing line, the digital zoom is being used. If it is below the line, the optical zoom is being used.
- Press “▲” or “▼” to move the “■” up and down.
- When you switch between digital zoom and optical zoom, the “■” stops moving briefly. Press the button for the same direction again to start the “■” moving and switch the zoom setting.
- ⚠ If the image goes out of focus when you use the zoom, press the shutter button down halfway to refocus.
- ⚠ The optical zoom is equivalent to approximately 38 mm-228 mm on a 35 mm camera.

⚡ FLASH

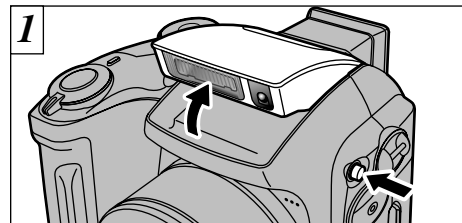

To change the flash setting, pop the flash unit up. The flash mode setting does not change when you close the flash.

● Effective flash range (in “AUTO” mode)

- Wide-angle: Approx. 0.3 m to 3.5 m
(1.0 ft. to 11.5 ft.)
- Telephoto : Approx. 0.8 m to 3.5 m
(2.6 ft. to 11.5 ft.)

- ⚠ When you pop the flash up, the image shown on the screen may disappear and the screen may go dark because the flash is charging. In this event, the indicator lamp blinks orange.
- ⚠ Using the flash in very dusty conditions or when it is snowing, white dots may appear in the image due to the flash reflecting off the dust particles or snowflakes. Try taking the shot using Suppressed Flash mode.

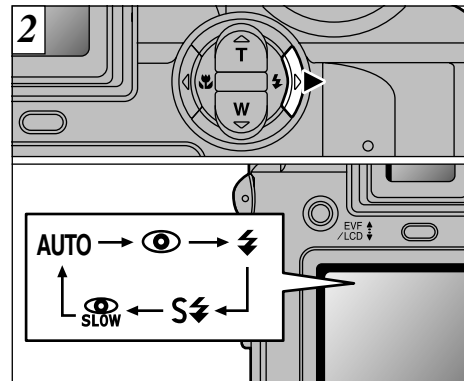

Press the “⚡” Flash button (▶) to select the flash mode to be used.

- ⚠ The flash charging time may increase if the charge remaining in the battery is low.

⚡ FLASH



Auto Flash Mode (no icon)

Use this mode for ordinary photography. The flash fires automatically as required by the shooting conditions.

⚠ If pressing the Shutter button while the flash is charging, the shot will be taken without the flash.

◆ Red-Eye Effect ◆

When you use the flash to photograph people in low-light conditions, their eyes sometimes appear red in the picture. This is caused by the light of the flash reflecting off the inside of the eye. Use Red-Eye Reduction flash to effectively minimize the likelihood of the red-eye effect.

Take the following measures also to make Red-Eye Reduction more effective:

- Get the subjects to look at the camera.
- Get as close as possible to the subjects.



👁 Red-Eye Reduction

Use this mode to ensure that the subject's eyes appear natural when photographing people in low-light conditions.

The flash fires a pre-flash just before the picture is taken and then fires again to take the actual picture.

⚠ If pressing the Shutter button while the flash is charging, the shot will be taken without the flash.



⚡ Forced Flash

Use this flash mode to photograph backlit scenes, such as a subject against a window or in the shade of a tree, or to obtain the correct colors when you are shooting under lighting such as fluorescent tubes. In this mode, the flash fires in bright as well as dark conditions.



⚡👁 Slow Synchro

This is a flash mode that uses a slow shutter speed. This allows you to take pictures of people at night that clearly show both your subjects and the night time backdrop. To prevent camera shake, always use a tripod.

- Slowest shutter speed
⌚ (SP night scene): Up to 3 sec.

👁👁 Red-Eye Reduction + Slow Synchro

Use this mode for slow synchro shots with red-eye reduction.

- ⚠ The image may be overexposed when you shoot bright scenes.

To take a picture of a main subject at night with the background brightly lit, please use the "👁" mode "⌚" (Night) settings (→P.45).

⚡ FLASH



Suppressed Flash

Pressing the flash down switches the camera to Suppressed Flash mode.

Use this mode for photography using indoor lighting, for shots taken through glass, and for photography in venues such as theaters or at indoor sporting events where the distance is too great for the flash to be effective.

When you use Suppressed Flash, the Automatic White Balance function (→P.125) operates so that natural colors are captured along with the ambience of the available light.

- ! If you are shooting in Suppressed Flash mode in dark conditions, use a tripod to prevent camera shake.
- ! See P.26, 117 for information on the camera shake warning.

◆ When you cannot change the flash settings ◆

- Check that the flash is popped up.

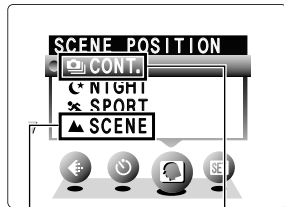

- When “▲” (Landscape) or “📷” (Continuous Shooting) is selected in “📷” (Scene Position) mode, the flash mode is set to “Suppressed Flash” even when the flash is popped up.

🌸 MACRO (CLOSE-UP) PHOTOGRAPHY

Selecting Macro mode allows you to take close-up shots.

● Effective Photography Range:

Approx. 10 cm to 80 cm (3.9 in. to 2.6 ft.)

- ! Macro photography is automatically cancelled in the following situations:
 - When you have switched photography modes
 - When the camera is switched off
- ! If you are shooting in a dark location (when the “!📷” camera shake warning icon is displayed), use a tripod to prevent camera shake.

◆ When you are using the flash ◆

When you use the flash in Macro mode, remove the lens adapter ring.

If the adapter ring is not removed, a shadow may appear in the bottom center of your shot.

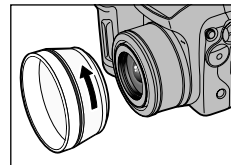

- Effective shooting range:
Approx. 30 to 80 cm
(1.0 ft. to 2.6 ft.)

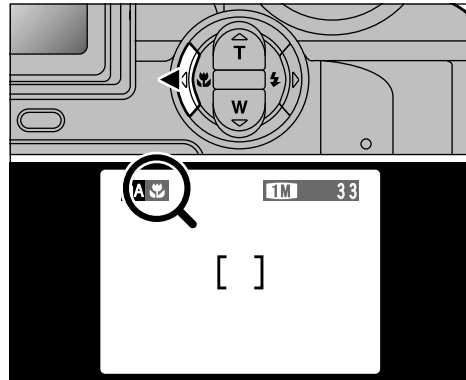

Press the “🌸” Macro button (◀). The “🌸” appears on the screen indicating that you can take close-up shots.

To cancel Macro mode, press the “🌸” Macro button (◀) again.

- ! In “📷” photography mode, you can only select the Macro setting for “📷” mode (Continuous shooting).

▶ PLAYBACK VIEWING YOUR IMAGES (PLAYBACK)

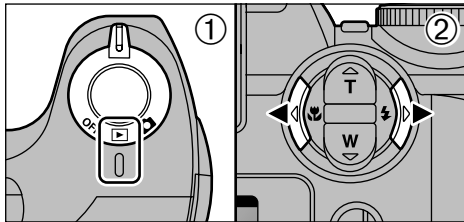

- 1 Set the Power switch to "▶".
- 2 Use the "◀" and "▶" to move forward and backward respectively through your images.

Fast Forwarding Images

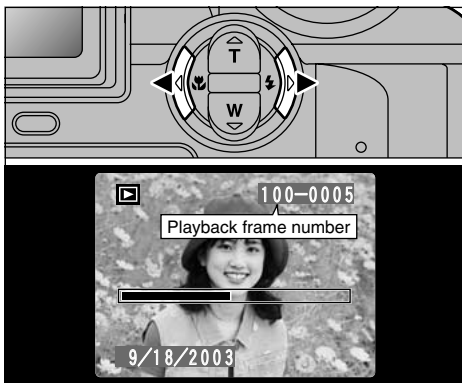

During playback, you can skip backwards or forwards through the images (the frame number increases or decreases) by holding down "◀" or "▶" for approximately 1 second.

The displayed image does not change, but a progress bar indicates the approximate playback location on the **xD-Picture Card**.

- ! When you set the Power switch to "▶", the last image shot is displayed.
- ! You can use this camera to play back still images recorded on an FinePix S3000 or still images (excluding some uncompressed images) recorded on any FUJIFILM digital camera that supports **xD-Picture Cards**.

▶ PLAYBACK MULTI-FRAME PLAYBACK

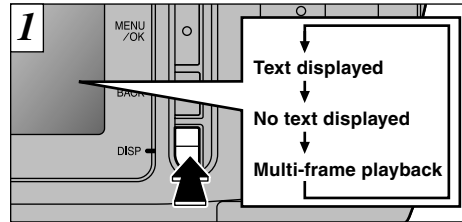

In playback mode, the display shown on the screen switches each time you press the "DISP" button. Press the "DISP" button until the multi-frame playback screen (9 frames) appears.

- ! The screen text display disappears after approximately 3 seconds.
- ! Playback zoom cannot be used with multi-frame playback.

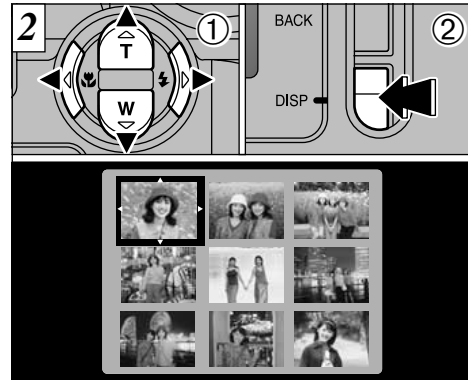

- 1 Select a frame by using "◀", "▶", "▲" and "▼" to move the cursor (the orange box) to the desired frame. Press "▲" or "▼" several times to switch to the previous page or the next page.
- 2 You can enlarge the selected image by pressing the "DISP" button again.

▶PLAYBACK **PLAYBACK ZOOM**

This function is useful for things such as checking the focus of shots you have taken. Pressing “▲” during single-frame playback switches you to the zoom screen.

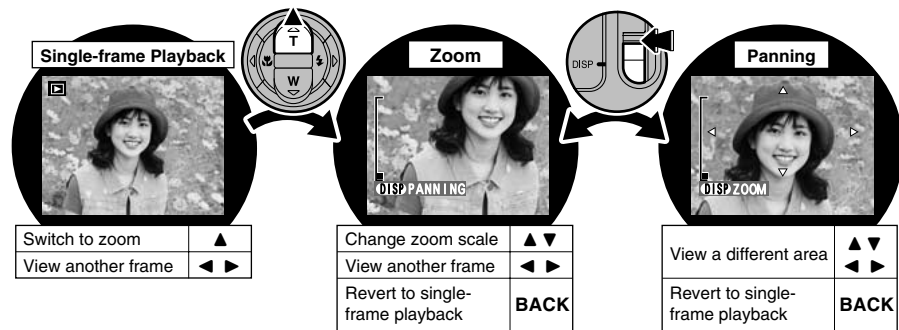

Quality	3M (2048 × 1536)	2M (1600 × 1200)	1M (1280 × 960)	0.3M (640 × 480)
Maximum Zoom Scale	13×	10×	8×	4×

⚠ It may not be possible to play back shots taken on other camera models.

40 ⚠ Playback zoom cannot be used during multi-frame playback.

▶PLAYBACK **ERASING SINGLE FRAME**

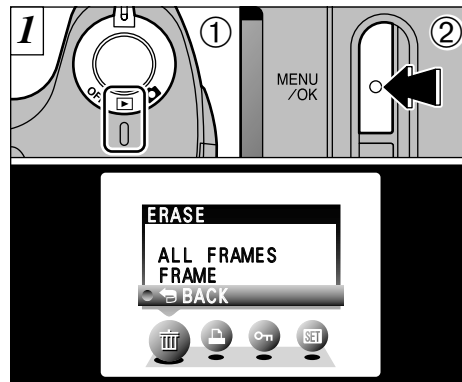

- ① Set the Power switch to “▶”.
 - ② Press the “MENU/OK” button to display the Menu on the screen.
- ⚠ To revert to image playback without erasing the image, select “BACK” and press the “MENU/OK” button.

Note that mistakenly erased images cannot be recovered. You should copy important files that you do not want to be erased to your computer or another media.

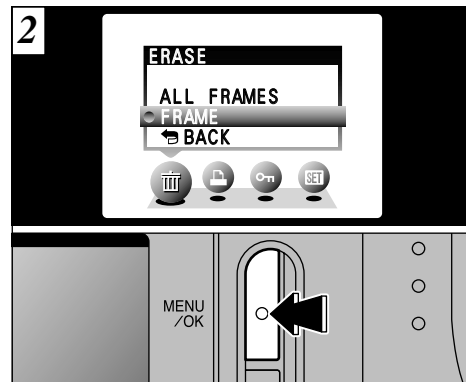

Press “▲” or “▼” to select “FRAME” in the “ERASE” menu and press the “MENU/OK” button. See P.61 for more information on “ALL FRAMES”.

2

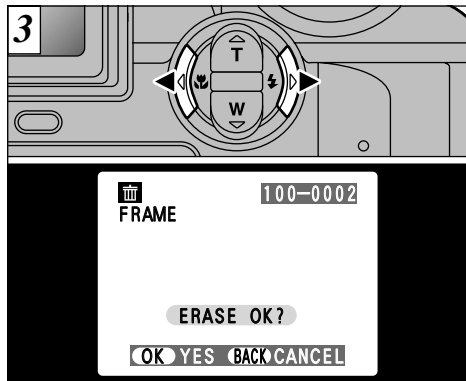

Press “◀” or “▶” to view the frame (selected file) you want to erase.

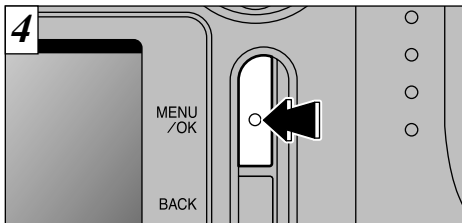

Pressing the “MENU/OK” button erases the frame (selected file) displayed. When erasing is complete, the next image appears and the “(ERASE OK?)” message is displayed.

To erase another frame, repeat steps 3 and 4. When you have finished erasing images, press the “BACK” button.

⚠ Pressing the “MENU/OK” button repeatedly erases consecutive images. Take care not to erase an image by mistake.

The Advanced Features Photography section introduces a range of camera functions that you can access by setting the Power switch to “”.

■ **Photography Mode Specifications**

		Default setting	(AUTO)	(SCENE POSITION)	(MANUAL)	(MOVIE)
▶	FLASH	—	OK	OK *1	OK	—
◀	MACRO	OFF	OK	— *2	OK	—
Menu	QUALITY	1M	OK	OK	OK	OK
	SELF-TIMER	OFF	OK	OK	OK	—
	SCENE POSITION	PORTRAIT	—	OK *1	—	—
	EV	0	—	—	OK	—
	WHITE BALANCE	AUTO	—	—	OK	—
	A.PRIORITY	AUTO	—	—	OK	—
	SHARPNESS	NORMAL	—	—	OK	—
	FLASH	0	—	—	OK	—
OPTION	—	OK	OK	OK	OK	

*1 Restrictions apply to the available flash modes depending on the “” Scene Position menu setting in “” mode (→P.45).

*2 In “” photography mode, you can only select the Macro setting for “” mode (Continuous shooting).

AUTO Auto mode

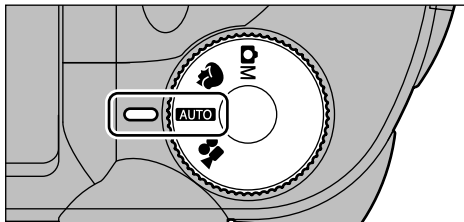

This is the simplest photography mode to use and is suitable for the widest range of shots.

M Manual mode

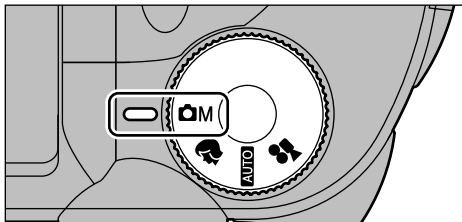

Manual mode lets you specify a range of different menu settings for taking pictures.

- **Menu options only available in Manual mode**
 Brightness (exposure compensation), white balance, aperture priority, sharpness, flash (flash brightness adjustment)

■ **Available menu options**

- | | |
|--------------|------------------|
| ◀ QUALITY | ⏸ SELF-TIMER |
| ☑ EV | WB WHITE BALANCE |
| A A.PRIORITY | S SHARPNESS |
| ⚡ FLASH | SET OPTION |

■ **Available menu options**

- ◀ QUALITY
- ⏸ SELF-TIMER
- SET OPTION

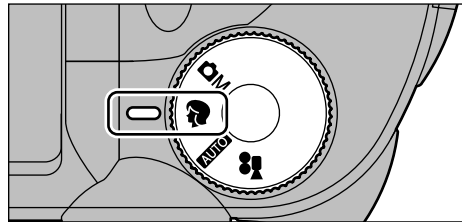

The “” Scene Position setting allows you to select any of 5 modes to suit the scene you are shooting. See P.46 for details.

■ **Available menu options**

- ◀ QUALITY
- ⏸ SELF-TIMER
-  SCENE POSITION
- SET OPTION

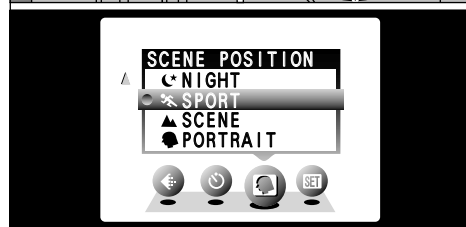
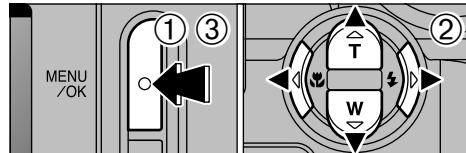

- ① Press the “MENU/OK” button to display the menu.
- ② Press “◀” or “▶” to select “” Scene Position and then press “▲” or “▼” to change the setting.
- ③ Press the “MENU/OK” button to confirm the selection.

Portrait

Use this mode for shots of people. Portrait mode provides soft-tone images with natural skin colors.

● **When using the flash**

Auto Flash, Red-Eye Reduction, Forced Flash, Slow Synchro, Red-Eye Reduction + Slow Synchro

Scene

Use this mode for daytime shots of scenery. Landscape mode provides crisp, clear shots of buildings, mountains and other scenery.

● **When using the flash**

The Flash mode is automatically set to Suppressed Flash. This setting cannot be changed.

Sport

Use this mode for moving objects.

● **Shutter**

Takes pictures using fast shutter speeds.

● **When using the flash**

Auto Flash or Forced Flash only

Night

Use this mode for shots taken in the evening or at night.

● **Shutter**

Slow shutter speed mode with speeds as slow as 3 seconds

● **When using the flash**

Slow Synchro, Red-Eye Reduction+Slow Synchro only

Cont.

Use this mode for continuous shooting without limiting the photographic scenes.

● **Number of continuous shots: 2**

● **Focusing Exposure, White Balance:**

Set when the first frame is shot.

● **Flash:** The flash is automatically set to Suppressed Flash mode.

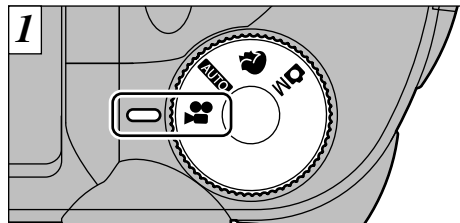

Set the Mode dial to “MOVIE”.

● **Specifications**

Motion JPEG without sound

● **Quality selection method**

320 (320 × 240 pixels)

160 (160 × 120 pixels)

● **Frame rate:** 10 frames per second

See P.125 for information on the frame rate.

⚠ See P.52 for information on changing the quality mode setting.

⚠ The available recording time for a movie may decrease depending on the amount of free space on the xD-Picture Card.

⚠ See P.124 for the available recording time with xD-Picture Cards.

⚠ You cannot switch the LCD monitor off in this mode.

It may not be possible to playback your movies on other cameras.

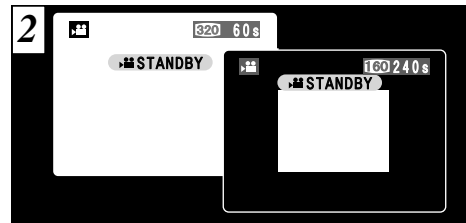

The available shooting time and the “STANDBY” message are shown on the screen.

⚠ When the quality mode is set to “160”, the image is displayed one size smaller. However, the area photographed does not change.

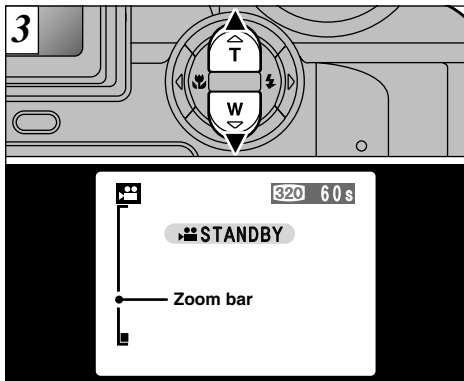

In Movie mode, the lens is locked at the wide-angle setting and only the digital zoom can be used. You can use “▲” (T TELE Zoom) and “▼” (W WIDE Zoom) to zoom in and out. A “zoom bar” is displayed on the screen.

Quality	Digital zoom focus distance (35 mm camera equivalent)	Max. Zoom Scale
320	Approx. 38 mm-120 mm	3.2×
160	Approx. 38 mm-120 mm	3.2×

Shots taken with the digital zoom have slightly lower image quality. Choose the zoom mode that best suits the scene being shot.

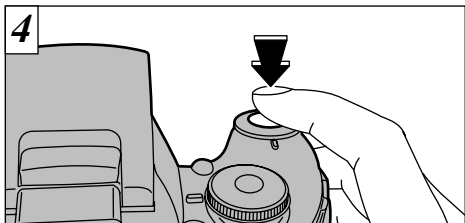

Shooting begins when you fully depress the Shutter button.

- When the camera is used to shoot a movie, you can get brighter images by using a light source such as a fluorescent lamp to illuminate the subject.
- You do not need to hold down the shutter button.
- The focus is fixed at 80 cm (2.6 ft.) to infinity.
- The focus and white balance remain fixed during shooting, but the exposure automatically changes to suit the scene.
- The image shown on the screen before you take the shot may differ in its brightness, color, etc. from the image shown on the monitor during movie recording.

The white balance is automatically set when you fully depress the Shutter button.

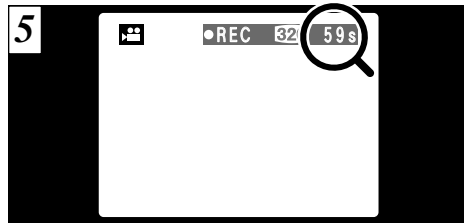

During shooting, “●REC” appears on the LCD monitor with a counter showing the remaining time displayed in the top-right corner.

Once the remaining time runs out, movie recording automatically stops and the movie is stored on the xD-Picture Card.

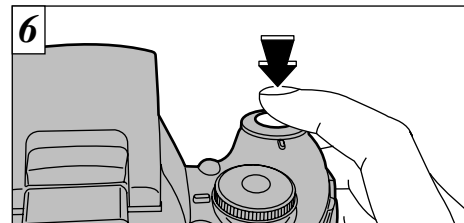

Pressing the Shutter button during shooting, shooting ends and the movie is stored on the xD-Picture Card.

If you end shooting immediately after you start shooting, only 1 second of movie is shot.

PHOTOGRAPHY MENU OPERATION

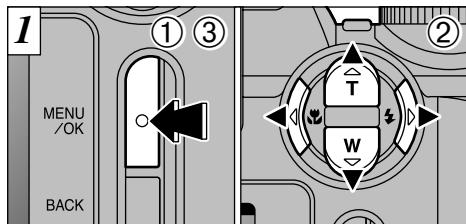

- ① Press the “MENU/OK” button to display the menu.
- ② Use “◀” and “▶” to select the menu item and “▲” and “▼” to change the setting.
- ③ Press the “MENU/OK” button to confirm the selection.

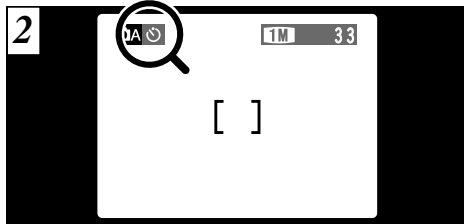

When you validate the settings, the respective icons appear at the top of the screen (Example showing the camera in AUTO mode with the self timer set.).

The accessible menu settings differ depending on the photography mode.

PHOTOGRAPHY MENU

◀: SETTING QUALITY MODE (NUMBER OF RECORDED PIXELS FOR IMAGES)

* Displaying the menus (→P.50)

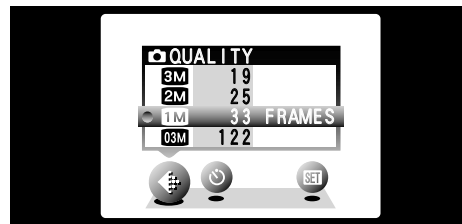

Use the “◀:” QUALITY setting to specify the number of recorded pixels.

Quality mode	Sample Uses
3M 3 MB (2048 × 1536)	Printing at A4 or A5 size or printing part of the image cropped at A6 size.
2M 2 MB (1600 × 1200)	Best for A6 or A5 size prints.
1M 1 MB (1280 × 960)	Best for A6 size prints.
0.3M 0.3 MB (640 × 480)	For an image attached to E-mail or used on a website.

◀ SETTING QUALITY MODE (NUMBER OF RECORDED PIXELS FOR IMAGES)

Still image (AUTO ·  · )

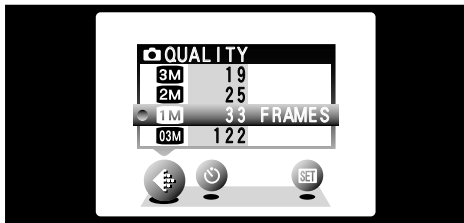

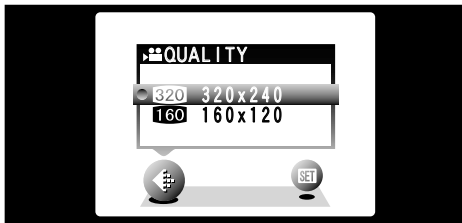

Any of 4 settings can be selected.
Choose the setting that best suits your needs.

Movie ()





You can select 2 levels of quality. For better image quality, select “320”, and for longer photography time, select “160”.

	Movie Size	Maximum shooting time
	320 × 240	60 sec.
	160 × 120	240 sec.

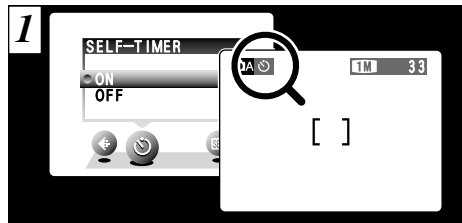

SELF-TIMER PHOTOGRAPHY * Displaying the menus (→P.50)



The self timer can be set in the “AUTO”, “” and “” modes.

When you set the self-timer to “ON”, “” appears on the screen.

In this mode, a timer runs for roughly 10 seconds before the shutter is released. Use this mode for shots such as photographs of yourself.

- ⚠ The self timer is automatically switched off in the following situations:
 - When shooting ends
 - When the Mode dial setting is changed
 - When the mode is switched between photography and playback
 - When the camera is switched off
- ⚠ You can also use the AF/AE lock (→P.29).
- ⚠ Be careful not to stand in front of the camera when you press the Shutter button as this can cause focusing or exposure metering errors.

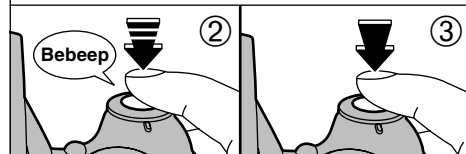

- ① Position the AF frame over your subject.
- ② Press the Shutter button down half way to set the focus.
- ③ Without releasing the Shutter button, press it down fully. The self-timer then starts running.

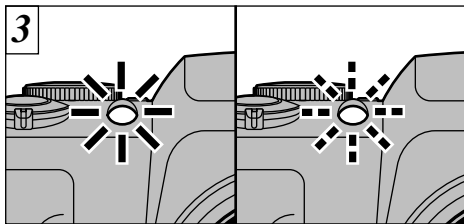

The self-timer lamp lights steadily for roughly 5 seconds and then blinks for another 5 seconds, after which the shot is taken.

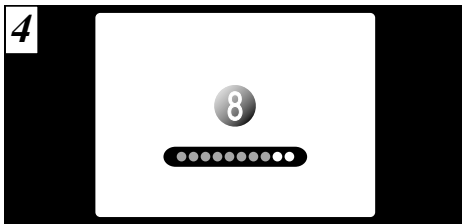

Until the picture is taken, a countdown appears on the screen. Self-timer mode is automatically cancelled after each shot.

54 To stop the self-timer once it has started running, press the “BACK” button.

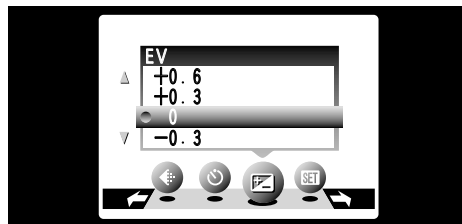

This mode can be selected in the “📷” photography mode.

Use the Exposure compensation setting to obtain the optimum image brightness (exposure) when the subject is much brighter or darker than the background.

● **Correction range:**

-2.1 EV to +1.5 EV
(13 steps: 0.3 EV increments)

See P.125 for more information on EV.

- The Exposure compensation setting is disabled in the following situations:
- When the flash is used in Auto or Red-Eye Reduction mode.
 - When dark scenes are shot in Forced Flash mode.

◆ **Subjects for Which Exposure Adjustment is Particularly Effective** ◆

Guide to using + (positive) compensation

- Copying of printed text (black characters on white paper) (+1.5 EV)
- Backlit portraits (+0.6 EV to +1.5 EV)
- Locations with very bright backgrounds or strong reflections, such as ski resorts: (+0.9 EV)
- Shots made up predominantly of sky: (+0.9 EV)

Guide to using - (negative) compensation

- Spotlight subjects, particularly against dark backgrounds (-0.6 EV)
- Copying of printed text (white characters on black paper) (-0.6 EV)
- Scenes with low reflectivity, such as shots of pine trees or dark foliage (-0.6 EV)

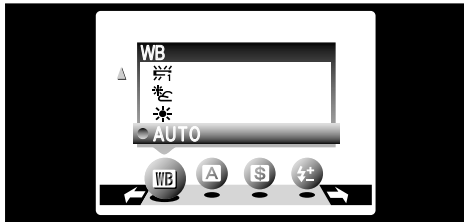
WB WHITE BALANCE (SELECTING THE LIGHT SOURCE) * Displaying the menus (→P.50)

This mode can be selected in the “📷” photography mode.

Change the white balance setting when you want to take a picture with the white balance fixed for the surroundings and lighting when the picture is taken.

In AUTO mode, the correct white balance may not be obtained for subjects such as close-ups of people’s faces and shots taken under a special light source. In such situations, select the correct white balance for the light source. See P.125 for information on the white balance.

AUTO: Automatic adjustment
(Shooting to show the ambience of the light source)

- ☀️ : Shooting outdoors in fine weather
- 🌿 : Shooting in shade
- 💡 : Shooting under “Daylight” fluorescent lamps
- 💡 : Shooting under “Warm White” fluorescent lamps
- 💡 : Shooting under “Cool White” fluorescent lamps
- 💡 : Shooting in incandescent light

* When the flash fires, the white balance set for the flash is used. To achieve a particular desired effect, set the flash mode to Suppressed Flash (→P.36).

⚠️ The color tones may vary somewhat depending on the shooting conditions (light source, etc.).

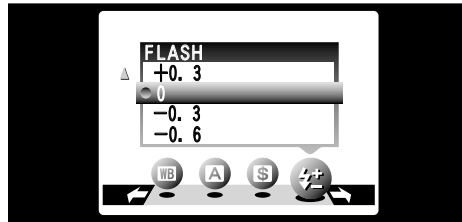
⚡ FLASH (FLASH BRIGHTNESS ADJUSTMENT)

This mode can be selected in the “📷” photography mode.

Flash brightness adjustment allows you to change only the amount of light emitted by the flash to suit the photography conditions or to achieve a desired effect.

● **Adjustment range:**

–0.6 to +0.6 EV
(5steps: 0.3 EV increments)

See P.125 for more information on EV.

⚠️ Depending on the subject and the shooting distance, adjusting the flash brightness may have little or no effect.

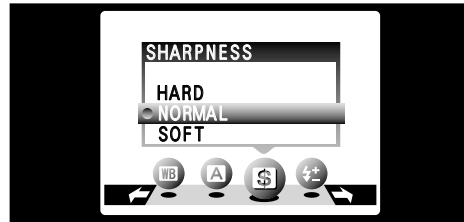
S SHARPNESS

This mode can be selected in the “📷” photography mode.

Use this setting to soften or emphasize outlines or to adjust the image quality.

● **3 levels of sharpness are available**

HARD : Emphasizes the outlines.
Best for shots of subjects such as buildings or text where you want sharp images.

NORMAL : Best for ordinary photography.
Provides edge sharpness that is ideal for ordinary shots.

SOFT : Softens the outlines.
Best for shots of subjects such as people, where a softer image is desirable.

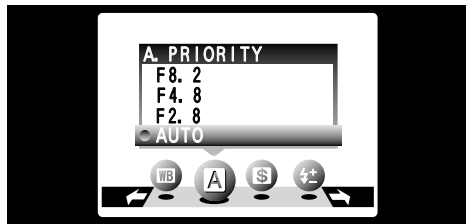

This mode can be selected in the “” photography mode.

This is an automatic mode that allows you to set the aperture. You can use this mode to take shots with a blurred background (wide aperture) or with both foreground and background in sharp focus (narrow aperture).

● **Aperture settings:** F2.8/F4.8/F8.2

Shutter speed (auto): 1/2 sec. to 1/1500 sec.

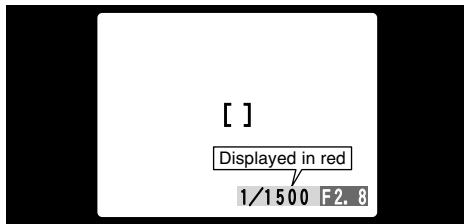

If the shutter speed is displayed in red when the Shutter button is pressed down halfway, the shot is overexposed or underexposed. Change the aperture setting until the correct exposure is obtained.

! Auto flash mode cannot be used in Aperture-Priority mode.

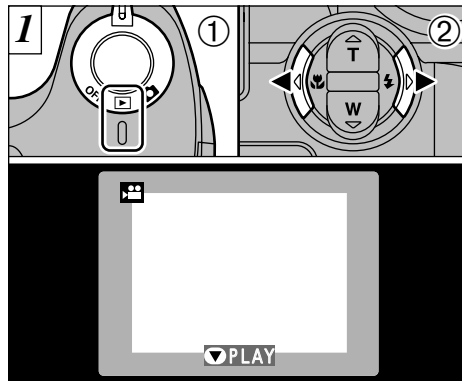

- ① Set the Power switch to “”.
- ② Use “” and “” to select the movie file.

! Movies cannot be played back using multi-frame playback. Use the “DISP” button to revert to normal playback.

Indicated by the “” icon.

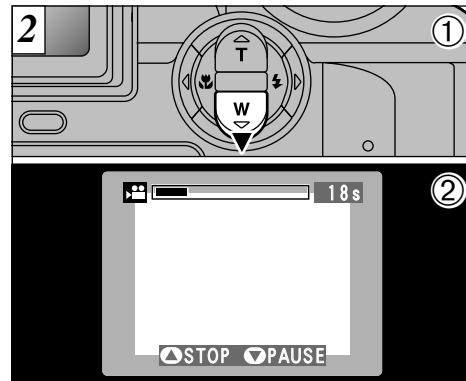





- ① Press “” to play the movie.
- ② The screen shows the playback time and a playback progress bar.

! If the subject of the movie is very bright, white streaks may appear on the image during playback. This is normal and is not a fault.

PLAYING BACK MOVIES (VIDEO)

■ Playing back movies

	Control	Description
Playback		Playback begins. The movie automatically stops when playback ends.
Pause/Resume		Pauses the movie during playback. Press this button again to resume playback.
Stop		Stops playback. * Press “◀” or “▶” while movie playback is stopped to go back to the previous file or advance to the next file respectively.
Fast forward/Rewind	 Rewind Fast forward	Press these during playback to skip forwards or backwards through the movie.
Skip playback	 When paused	<ul style="list-style-type: none"> • Each time you press “◀” or “▶” when the movie is paused, the movie advances or goes back one frame. • Hold down the button to move through the frames quickly.

◆ Playing back movie files ◆

- It may not be possible to play back a movie file that was recorded on a camera other than the FinePix S3000.
- To play back movie files on a computer, save the movie file on the **xD-Picture Card** to the computer's hard disk and then play back the saved file.

▶ **PLAYBACK MENU**



ERASING SINGLE/ALL FRAMES

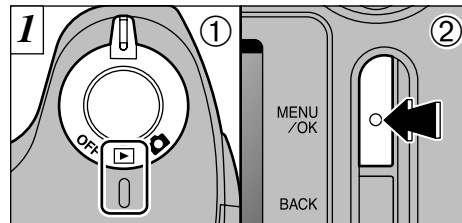

- ① Set the Power switch to “▶”.
- ② Press the “MENU/OK” button to view the menu screen.

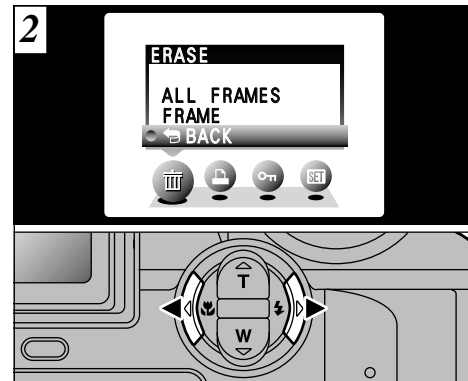

Use “◀” and “▶” to select “” ERASE.

Note that mistakenly erased images cannot be recovered. You should copy important files that you do not want to be erased to your computer or another media.

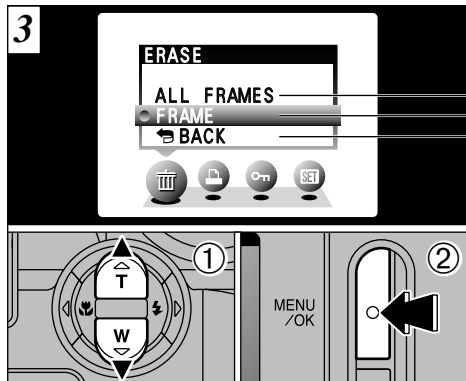

- ① Use “▲” and “▼” to select “FRAME” or “ALL FRAMES”.
- ② Press “MENU/OK” button to confirm your selection.

ALL FRAMES

Erases all unprotected files. You should copy important files that you do not want to be erased to your computer or another media.

FRAME

Erase only the selected file.

BACK

Returns to playback without erasing any files.

FRAME

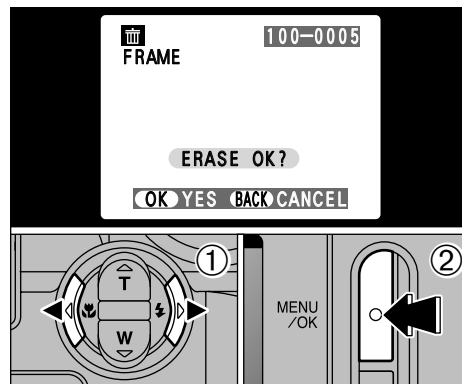

- ① Use “◀” and “▶” to select the file to be erased.
- ② Press the “MENU/OK” button to erase the currently displayed file.

To erase another image, repeat steps ① and ②. When you have finished erasing images, press the “BACK” button.

- ⚠ The file for which “PROTECTED FRAME” was displayed cannot be erased. Remove the protection.

ALL FRAMES

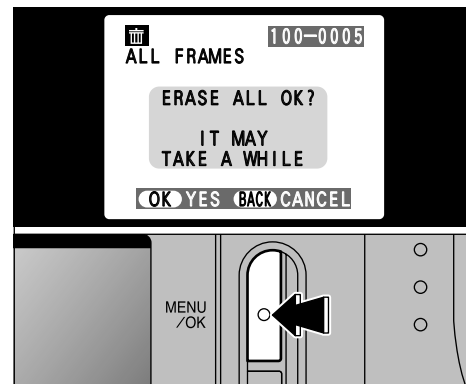

Pressing the “MENU/OK” button erases all the unprotected files.

If the “DPOF SPECIFIED. ERASE OK?” or “DPOF SPECIFIED. ERASE ALL OK?” message appears, press the “MENU/OK” button once more to erase the image.



◆ To stop the procedure mid-way ◆

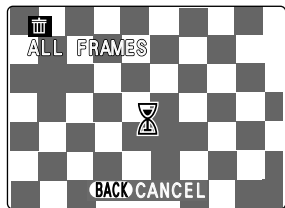

Press the “BACK” button to stop erasing all the frames. Some unprotected frames (files) will be left unerased.

⚠ Even if you stop the procedure immediately, some frames (files) will be erased.

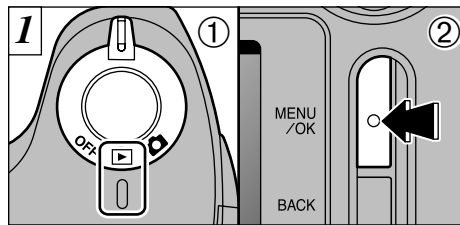

- ① Set the Power switch to “▶”.
- ② Press the “MENU/OK” button to view the menu screen.

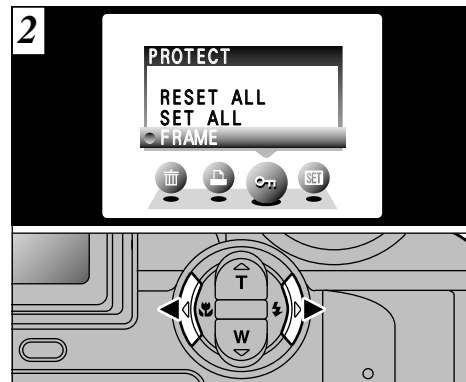

Use “◀” and “▶” to select “” PROTECT.

Protection is a setting that prevents frames (files) from being accidentally erased. However, the “FORMAT” function erases all the frames (files), including protected frames (files) (→P.80).

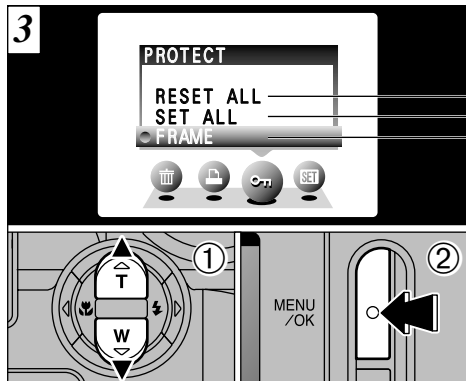

- ① Press “▲” or “▼” to select “RESET ALL”, “SET ALL” or “FRAME”.
- ② Press “MENU/OK” button to confirm your selection.

RESET ALL

Removes the protection from all the files.

SET ALL

Protects all the files.

FRAME

Protects or unprotects only the selected file.

FRAME SET

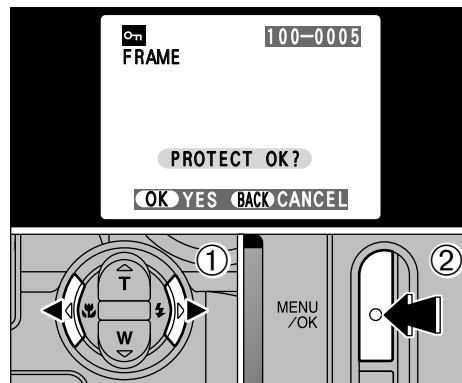

- ① Press “◀” or “▶” to select the file to be protected.
 - ② Press the “MENU/OK” button to protect the file currently displayed.
- To protect another file, repeat steps ① and ②. To finish protecting files, press the “BACK” button.

FRAME RESET

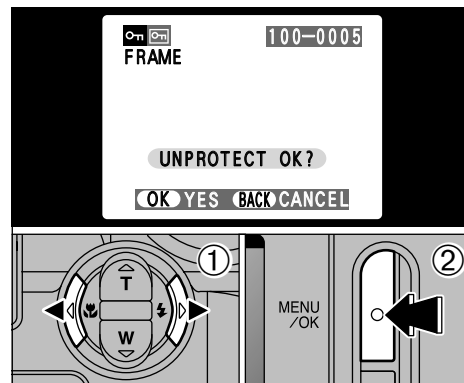

- ① Press “◀” or “▶” to select the protected frame (file).
- ② Press the “MENU/OK” button to unprotect the displayed frame (file).

SET ALL

Press the “MENU/OK” button to protect all the files.

RESET ALL

Press the “MENU/OK” button to unprotect all the files.

◆ To stop the procedure mid-way ◆

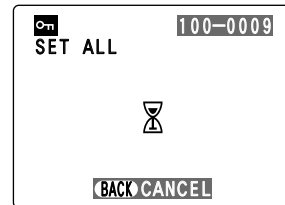

If a large number of images are recorded in the **xD-Picture Card**, protecting or unprotecting all the frames may take some time.

If you want to shoot a picture or a movie during the procedure, press the “BACK” button. To then return to protecting or unprotecting all the frames, start the procedure on P.65 from step 7.

! To interrupt the procedure before it is completed, press the “BACK” button.

! To interrupt the procedure before it is completed, press the “BACK” button.



DPOF stands for Digital Print Order Format and refers to a format that is used for recording printing specifications for images shot using a digital camera on media such as **xD-Picture Card**. The recorded specifications include information on which frames are to be printed.

This section gives a detailed description of how to order your prints with the FinePix S3000. On the FinePix S3000, you can specify only one print per image in the DPOF settings.

- * Note that some printers do not support date and time imprinting or specification of the number of prints.
- * Note that the warnings shown below may be displayed while you are specifying the prints.

DPOF SPECIFIED. ERASE OK ?

DPOF SPECIFIED. ERASE ALL OK ? (→P.63)

When you erase the image, the DPOF setting for that image is deleted at the same time.

RESET DPOF OK ? (→P.72)

If you insert an **xD-Picture Card** that contains frames specified for printing on another camera, those print specifications are all reset and replaced by the new print specifications.

DPOF FILE ERROR (→P.119)

Up to 999 frames can be specified on the same **xD-Picture Card**.

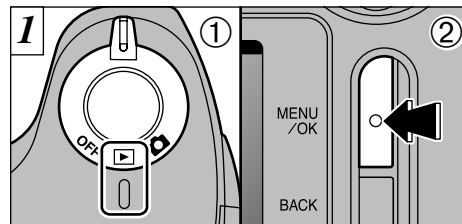

- ① Set the Power switch to “▶”.
- ② Press the “MENU/OK” button.

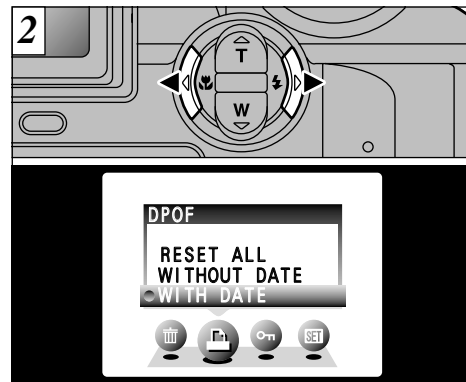

Press “◀” or “▶” to select “ DPOF.

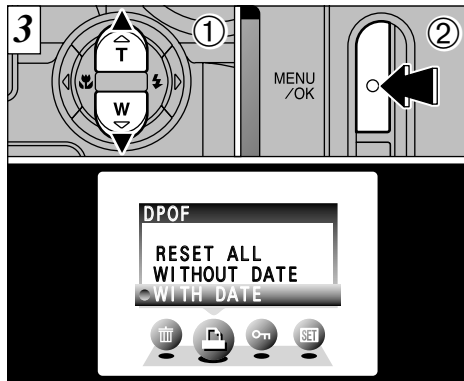

- ① Press “▲” or “▼” to select “WITH DATE” or “WITHOUT DATE”. By selecting the “WITH DATE”, the date is imprinted on your prints.
- ② Press the “MENU/OK” button.

⚠ By selecting the “WITH DATE” setting, you can have the date imprinted on your shots when you use the Print Service or a DPOF-compatible printer. (Depending on the printer specifications, the date may not be printed in some cases.)

◆ **When DPOF settings were specified on another camera** ◆



When the data includes a frame with DPOF setting that were specified on another camera, “RESET DPOF OK?” appears. Pressing the “MENU/OK” button erases all of the DPOF settings already specified for each frame. You must then specify the DPOF setting for each frame again.

- ⚠ Press the “BACK” button to leave the previous settings unchanged.

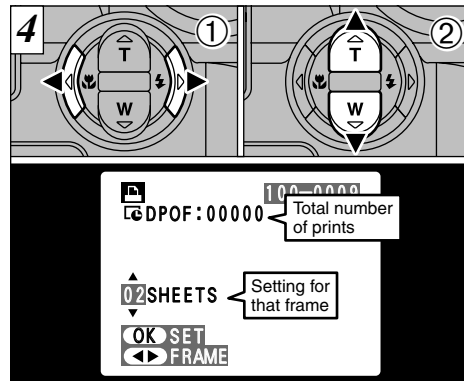

- ① Press “◀” or “▶” to display the frame (file) for which you want to specify DPOF settings.
- ② Press “▲” or “▼” to set a value up to 99 as the number of copies of the frame (file) to be printed. For frames (files) that you do not want printed, set the number of prints to 0 (zero). To specify more DPOF settings, repeat steps ① and ②.
- ⚠ You can order prints of up to 999 image frames on the same xD-Picture Card.
- ⚠ DPOF settings cannot be specified for movies.

Pressing the “BACK” button during the settings, all the new settings are cancelled. If there were previous DPOF settings, only the modifications are cancelled.

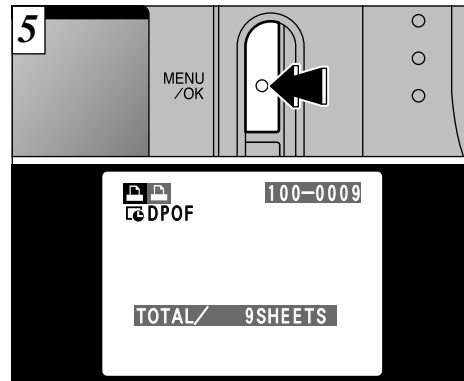

Always press the “MENU/OK” button when you complete the settings. Pressing the “BACK” button, no DPOF settings are specified.

◆ **Cancelling a frame** ◆

To cancel the DPOF setting for a frame you have specified (cancel frame), perform steps ① to ③ and then ① press “◀” or “▶” to select the frame with the DPOF setting you want to cancel and then ② set the number of prints to 0 (zero). To cancel the DPOF setting for another frame, repeat steps ① and ②. When you have completed the settings, you must press the “MENU/OK” button.

DPOF SET FRAME (RESET ALL)

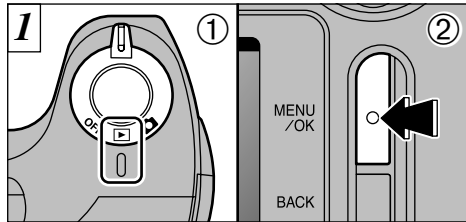

- ① Set the Power switch to "▶".
- ② Press the "MENU/OK" button.

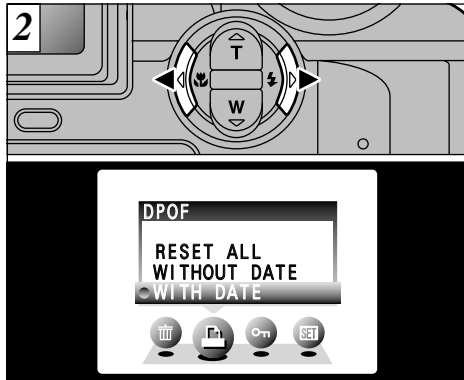

Press "◀" or "▶" to select "📄" DPOF.

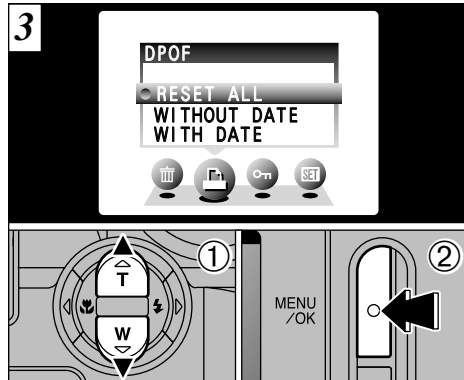

- ① Press "▲" or "▼" to select "RESET ALL".
- ② Press the "MENU/OK" button.

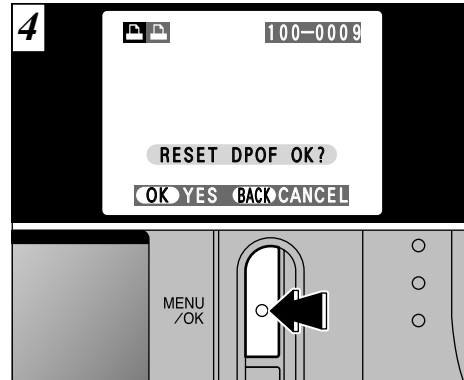

A confirmation message appears. To reset all the DPOF settings, press the "MENU/OK" button.

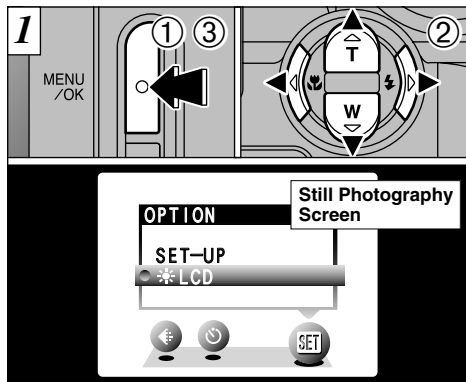

You can use “*LCD” in any mode.

- 1 Press the “MENU/OK” button to display the menu screen.
- 2 Press “◀” or “▶” to select “SET” OPTION and then press “▲” or “▼” to select “*LCD”.
- 3 Press the “MENU/OK” button.

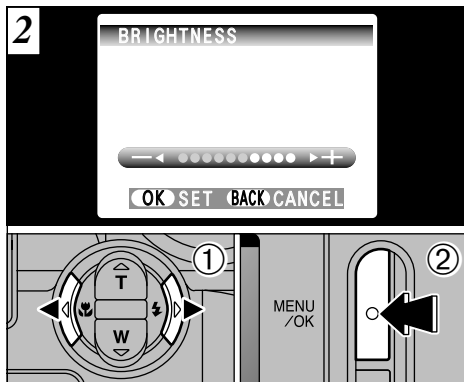

- 1 Use “◀” and “▶” to adjust the screen brightness.
- 2 Press the “MENU/OK” button to confirm the new setting.

! To exit this procedure without changing the settings, press the “BACK” button.

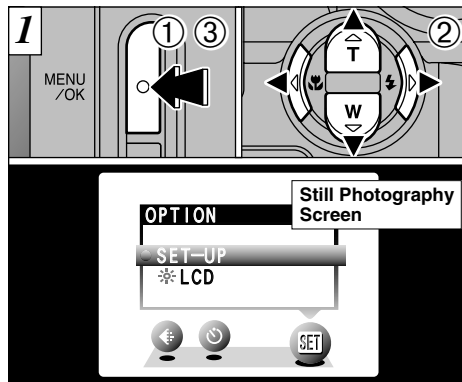

You can use “SET-UP” in any mode.

- 1 Press the “MENU/OK” button to display the menu screen.
- 2 Press “◀” or “▶” to select “SET” OPTION and then press “▲” or “▼” to select “SET-UP”.
- 3 Press the “MENU/OK” button.

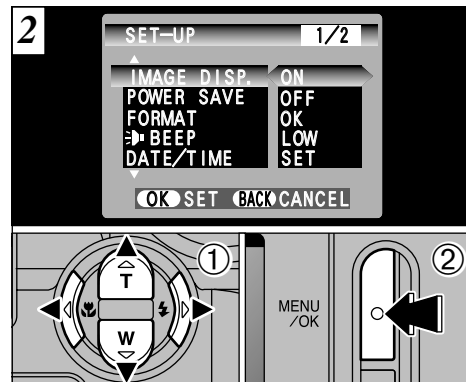

- 1 Press “▲” or “▼” to select a menu option and then press “◀” or “▶” to change the setting.
- 2 Press the “MENU/OK” button.

! Press “▶” for “FORMAT”, “DATE/TIME” or “RESET”.

SET-UP Menu Options

Settings	Display	Default setting	Explanation
IMAGE DISP.	ON/OFF	ON	This option specifies whether or not an image checking screen (photography results) is displayed after you take a shot. The photographed image is displayed for a few moments and then automatically recorded. In continuous shooting, the photography results are displayed for a set time before being automatically recorded even if this option is set to "OFF".
POWER SAVE	ON/OFF	OFF	This function temporarily switches the screen off if the camera is not used for approximately 30 seconds. See P.79 for details.
FORMAT	OK	—	Erases all files. See P.80 for details.
BEEP	LOW/HIGH/OFF	LOW	Sets the volume of the tone emitted when the camera controls are used.
DATE/TIME	SET	—	Use this option to correct the date or time. See P.18 for details.
USB MODE	PC	PC	Selects the function when the camera is connected to a PC. See P.97 for details.
LANGUAGE	ENGLISH/ FRANCAIS/DEUTSCH/ ESPAÑOL/中文	ENGLISH	Use this setting to specify the language used for LCD monitor display.
VIDEO SYSTEM	NTSC/PAL	—	Specifies whether video output is set to NTSC or PAL.
RESET	OK	—	Resets all the camera settings other than the date and time, language and video output settings to the factory default values set at shipment. Pressing "▶" displays a confirmation screen. To reset the settings, press the "MENU/OK" button.

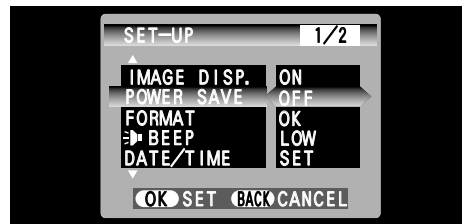

Power saving "OFF" (default setting)

The camera does not use measures such as "sleep" to reduce power consumption. However, if the camera is not used for approximately 2 minutes, this function automatically switches the camera off.

Power saving "ON"

Power consumption is kept to a minimum to prevent battery depletion.

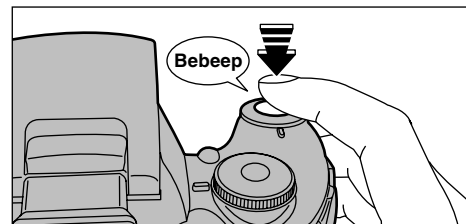
- If the camera is not used for approximately 30 seconds, the screen switches off temporarily to reduce power consumption (Sleep mode).
- Once the camera is in Sleep mode, if it is left unused for a further 90 seconds, it is automatically switched off.
- The charging time for the flash increases slightly because the flash charging power is reduced.



When the camera is in sleep mode, pressing the Shutter button down halfway brings the camera back to full operational mode. This is a useful feature as it allows you to take pictures more quickly than switching the camera off and then on again. You can also take a picture by pressing the Shutter button all the way down.

! Operation can also be restored by pressing buttons other than the Shutter button.

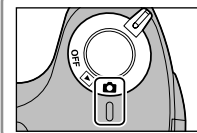
To restore power to the camera

Turn the Power switch to "OFF" briefly and then back to "▶".

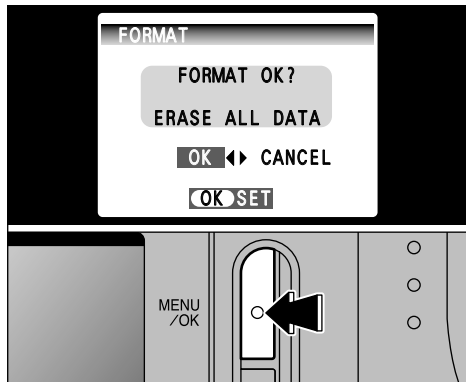

Formatting erases all the frames (files). Initialize the **xD-Picture Card** for use in the camera. Copy important files onto your computer or another media.

- ① Press “◀” or “▶” to select “OK”.
- ② Press the “MENU/OK” button to erase all the files and format the **xD-Picture Card**.

Formatting erases protected files also.

⚠ If the “CARD ERROR” “WRITE ERROR” “READ ERROR” or “CARD NOT INITIALIZED” message appears before formatting the media, refer to P.117-118 and take the appropriate measures.

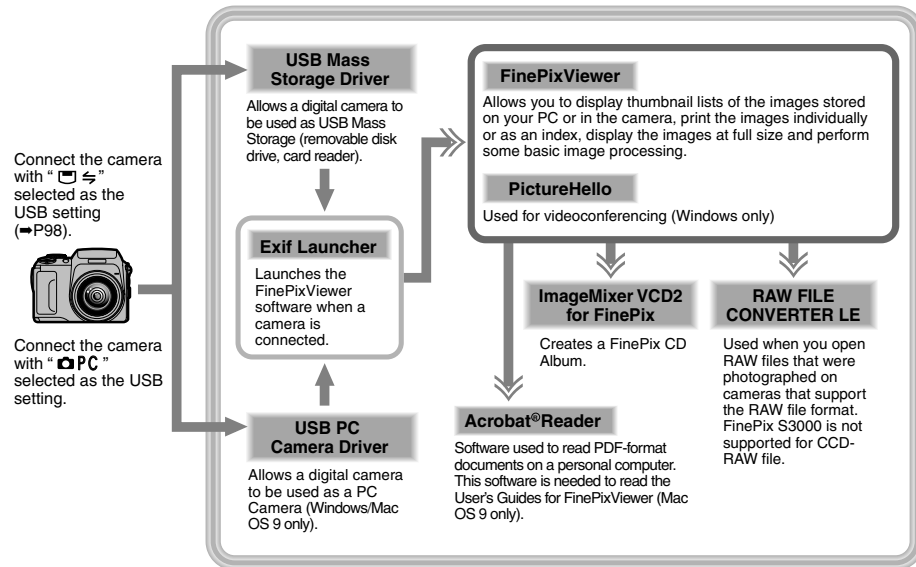

* Note that the software configuration differs slightly depending on your operating system.

6.2 INSTALLATION ON A Windows PC

Pre-installation checklist (For Windows)

To run this software, you must have the hardware and software described below. Check your system before you begin the installation.

Compatible PCs	IBM PC/AT or compatible*1
Operating System	Windows 98 (including the Second Edition) Windows Millennium Edition (Windows Me) Windows 2000 Professional*2 Windows XP Home Edition*2 Windows XP Professional*2
CPU	200 MHz Pentium or better recommended (800 MHz Pentium III or better recommended for Windows XP)
RAM	64 MB minimum (128 MB minimum for Windows XP), 256 MB or more recommended
Hard disk space	Amount required for installation: 450 MB minimum Amount required for operation: 600 MB minimum (When ImageMixer VCD2 for FinePix is used: 2 GB or better)
Display	800 × 600 pixels or better, 16-bit color or better (When ImageMixer VCD2 for FinePix is used: 1024 × 768 or better)
Internet connection*3	<ul style="list-style-type: none">• To use FinePix Internet Service, videoconferencing or mail attachment function An Internet connection and e-mail transmission software• Connection speed: 56k or better recommended
Sound functions*4	Speakers, microphone and sound card

*1 Models with a USB interface as a standard feature and one of the above operating systems preinstalled.

*2 When you install the software, log in using a system administrator account (e.g. "Administrator").

*3 Required to use the FinePix Internet Service and videoconferencing. The software can still be installed even if you do not have an Internet connection.

*4 Sound functions are required for videoconferencing.

Note

- Connect the camera directly to the computer using the USB cable (included). The software may not operate correctly if you use an extension cable or connect the camera via a USB hub.
- If your computer has more than one USB port, the camera can be connected to either port.
- Push the USB connector fully into the socket to ensure that it is securely connected. The software may not operate correctly if the connection is faulty.
- Additional USB interface board is not guaranteed.
- Windows 95 cannot be used.
- Operation is not guaranteed on home-built computers or on computers running updated operating system software.
- If your Internet connection is via a router or via a LAN (connecting machines on the LAN to the Internet), you cannot use videoconferencing.
- If you are using Windows XP and you tick the "Protect my computer and network by limiting or preventing access to this computer from the Internet" checkbox in the Internet connection firewall settings, videoconferencing cannot be used.
- When you reinstall or remove FinePixViewer, the Internet menu and your user ID and password for the FinePix Internet Service are deleted from your computer. Click the [Register now] button, enter your registered user ID and password and download the menu again.

6.2 INSTALLATION ON A Windows PC

Do not connect the camera to your PC until the software installation is completed.

1 Install FinePixViewer as instructed in the Quick Start Guide.

◆ Launching the Installer Manually ◆

- ① Double-click the "My Computer" icon.
* Windows XP users should click "My Computer" in the "Start" menu.
- ② Right-click "FINEPIX" (CD-ROM drive) in the "My Computer" window and select "Open".
- ③ Double-click "SETUP" or "SETUP.exe" in the CD-ROM window.

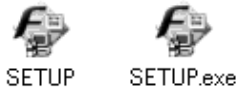

- * The way file names are displayed differs as described below depending on your computer settings.
- File extensions (3-letter suffixes indicating the file type) may be shown or hidden. (e.g. Setup.exe or Setup)
 - Text may be shown normally or all in uppercase (e.g. Setup or SETUP).

◆ Installing Other Applications ◆

You may see messages for installing NetMeeting, ImageMixer VCD2 for FinePix and WINASPI. Install these applications as directed by the on-screen instructions. The installation screens for these applications are displayed as required.

2 After restarting your PC, install DirectX as directed by the on-screen instructions and then restart your PC again. If the latest version of DirectX is already installed on your PC, this installation is not performed.

3 After restarting your PC, the "FinePixViewer installation completed" message appears.

6.3 INSTALLATION ON A Mac OS 9.0 TO 9.2

Pre-installation Checklist

To run this software, you must have the hardware and software described below. Check your system before you begin the installation.

Compatible Mac	Power Macintosh G3*1, PowerBook G3*1, Power Macintosh G4, iMac, iBook, Power Macintosh G4 Cube or PowerBook G4
Operating System	Mac OS 9.0 to 9.2.2*2
RAM	64 MB minimum*3, 256 MB or more recommended (When ImageMixer VCD2 for FinePix is used: 128 MB or better)
Hard disk space	Amount required for installation: 400 MB minimum Amount required for operation: 600 MB minimum (When ImageMixer VCD2 for FinePix is used: 2 GB or better)
Display	800 × 600 pixels or better, at least 32,000 colors (When ImageMixer VCD2 for FinePix is used: 1024 × 768 or better)
Internet connection*4	<ul style="list-style-type: none">• To use the FinePix Internet Service or mail attachment function An Internet connection and e-mail transmission software• Connection speed: 56k or better recommended
Sound functions	Speakers and microphone

*1 Models with a USB port as a standard feature

*2 This software does not run correctly in the Mac OS X Classic environment.

*3 Turn virtual memory on if necessary.

*4 Required to use the FinePix Internet Service. The software can still be installed even if you do not have an Internet connection.

6.3 INSTALLATION ON A Mac OS 9.0 TO 9.2

◆ Note ◆

- Connect the camera directly to the Macintosh using the USB cable (included). The software may not operate correctly if you use an extension cable or connect the camera via a USB hub.
- Push the USB connector fully into the socket to ensure that it is securely connected. The software may not operate correctly if the connection is faulty.
- Additional USB interface board is not guaranteed.
- On Macintosh computers, allocate at least 400 MB of virtual memory when RAW FILE CONVERTER LE is used. If other applications will be used at the same time, allocate the additional amount required for those applications also.

◆ Enable File Exchange ◆

Check whether File Exchange is active.

To use an **xD-Picture Card** that is supported by the camera, the File Exchange utility supplied with Mac OS must be running.

- 1 Switch on your Macintosh and start up Mac OS 9.0 to 9.2.
 - Do not connect the camera to your Macintosh until the software installation is completed.
- 2 Select the Extension Manager in the Control Panel and check that the File Exchange check box is ticked. If not, click in the box so that “” appears and then restart your Macintosh.
- 3 When you load the enclosed CD-ROM into the CD-ROM drive, the “FinePix” window automatically opens.
 - If the “FinePix” window does not open automatically, double-click the CD-ROM icon.
- 4 Double-click “Installer for MacOS9” to launch the Installer.

- 5 The Installer setup screen appears. Click the [Installing FinePixViewer] button.

- For more information on what is installed, click the [Read Me First] button and [Using FinePixViewer] button.



- 6 A confirmation message appears asking whether you want to continue with the installation. Click the [OK] button.
- 7 The User License Agreement for this software is displayed. Read the agreement carefully and then, if you agree to the terms of the Agreement, click the [Agree] button. If you click the [Disagree] button, the software is not installed.

6.3 INSTALLATION ON A Mac OS 9.0 TO 9.2

8 Select the installation destination for FinePixViewer.

- 1 Click the [Open] button to open the installation destination folder.

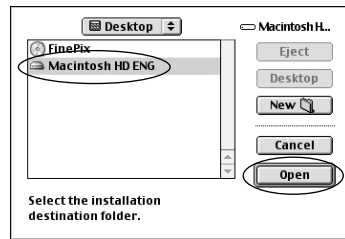

- 2 Click the [Save] button.

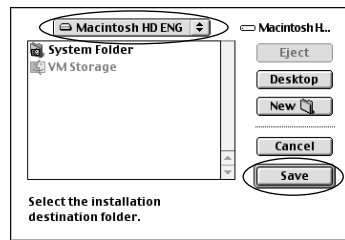

9 Install ImageMixer VCD2 for FinePix as directed by the on-screen instructions.

10 After restarting your Macintosh, the “FinePixViewer installation completed” message appears. Click “Using FinePixViewer” to view the basic FinePixViewer functions.



11 To install Acrobat Reader, click “Install Acrobat Reader”.

- 1 Install Adobe Systems' Acrobat Reader software to read the FinePixViewer User's Guide (PDF). The latest version has been installed, this step is not required.

12 Proceed with the installation as directed by the on-screen instructions.

◆ To install Acrobat Reader later... ◆

- 1 Double-click the “FinePix” CD-ROM to open the CD-ROM window.
- 2 Double-click “FinePixViewer for MacOS9” → “Acrobat Reader” → “English” folder.
- 3 Double-click “English Reader Installer”.
- 4 Proceed with the installation as directed by the on-screen instructions.

6.4 INSTALLATION ON A Mac OS X

Pre-installation Checklist

■ Hardware and software requirements

To run this software, you must have the hardware and software described below. Check your system before you begin the installation.

Compatible Mac	Power Macintosh G3*1, PowerBook G3*1, Power Macintosh G4, iMac, iBook, Power Macintosh G4 Cube, or PowerBook G4
Operating System	Mac OS X (compatible with version 10.1.5 to 10.2.6)
RAM	192 MB minimum , 256 MB or more recommended
Hard disk space	Amount required for installation: 200 MB minimum Amount required for operation: 400 MB minimum (When ImageMixer VCD2 for FinePix is used: 2GB or better)
Display	800 × 600 pixels or better, at least 32,000 colors (When ImageMixer VCD2 for FinePix is used: 1024 × 768 or better)
Internet connection*2	<ul style="list-style-type: none">• To use the FinePix Internet Service or mail attachment function An Internet connection and e-mail transmission software• Connection speed: 56k or better recommended

*1 Models with a USB port as a standard feature

*2 Required to use the FinePix Internet Service. The software can still be installed even if you do not have an Internet connection.

◆ Note ◆

- Connect the camera directly to the Macintosh using the USB cable (included). The software may not operate correctly if you use an extension cable or connect the camera via a USB hub.
- Push the USB connector fully into the socket to ensure that it is securely connected. The software may not operate correctly if the connection is faulty.
- Additional USB interface board is not guaranteed.
- On Macintosh computers, allocate at least 400 MB of virtual memory when RAW FILE CONVERTER LE is used. If other applications will be used at the same time, allocate the additional amount required for those applications also.

■ Functions not supported in FinePixViewer for Mac OS X

Function	Comment
PC Camera	Not supported.
Online updating	Information on updates can not be obtained using [Support] in the Internet menu.

6.4 INSTALLATION ON A Mac OS X

FinePixViewer and RAW FILE CONVERTER LE are installed on Mac OS X.

1 Switch your Macintosh on and start up Mac OS X. Do not launch any other applications.

2 Load the enclosed CD-ROM into the CD-ROM drive.
The “FinePix” window opens.

• If the “FinePix” window does not open automatically, double-click the CD-ROM icon.



3 Double-click “Installer for MacOS X”.

4 Click the “” icon.
(This operation is not required on version 10.2 (or later).)



5 Enter the administrator name and password.
Then click the [OK] button.

• The window displayed in Mac OS X is slightly different.

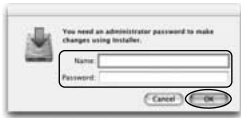

6 Click the [Continue] button.

7 Quit any other programs that are running and then click the [Continue] button.

8 Click the [Continue] button in the “Software License Agreement” window.

9 Click the [Continue] button.

• The software is installed in the “Applications” folder on the installation destination disk.

10 Click the [Install (upgrade)] button.

11 Enter your administrator name and password and then click [OK].

12 An installation progress window appears.
(Installation may take several minutes)

13 When you have completed the installation, click the [Restart] button.



6.4 INSTALLATION ON A Mac OS X

14 Launch "Image Capture" from the "Applications" folder.

15 Change the ImageCapture settings.
(OS X 10.1.5)

(1) Select "Other..." from "Hot plug Action".

(OS X 10.2 or later)

(1) Select "Preferenes..." from the "Image Capture" menu.

(2) Select "Other..." from "When a camera is connected, open".

16 Select "FPVBridge" from "FinePixViewer" folder in the "Applications" folder and click the "Open" button.

17 Quit ImageCapture.



7 Viewing Images

7.1 CAMERA CONNECTION

7.1.1 Using the AC power adapter (sold separately)

Always use a FUJIFILM AC Power Adapter AC-5VH/AC-5VHS (➔P.109).

Use the AC power adapter to avoid losing power at inconvenient times, such as when downloading photographed images to the computer. Using the AC power adapter also allows you to take pictures and play back images without worrying about depleting the batteries.

⚠ Only connect or disconnect the AC power adapter when the camera is switched off. Connecting or disconnecting the AC power adapter while the camera is switched on temporarily interrupts the power supply to the camera, so that images or movies being shot at the time are not recorded. Failing to switch the camera off first can also result in damage to the **xD-Picture Card** or malfunctions during PC connection.

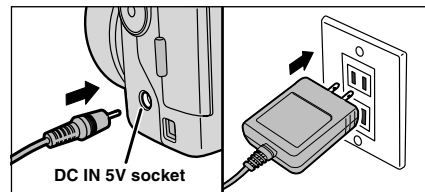

Check that the camera is switched off. Plug the AC power adapter connector into the "DC IN 5V" socket and then plug the AC power adapter into the power outlet.

- ⚠ The socket-outlet shall be installed near the equipment and shall be easily accessible.
- ⚠ The shape of the plug and socket-outlet depends on the country of use.
- ⚠ See P.114 for notes on using the AC power adapter.

Connecting the AC power adapter does not allow you to charge the Ni-MH batteries. Use the optional charger (➔P.109) to charge the Ni-MH batteries.

7.1 CAMERA CONNECTION

7.1.2 Connecting to a TV

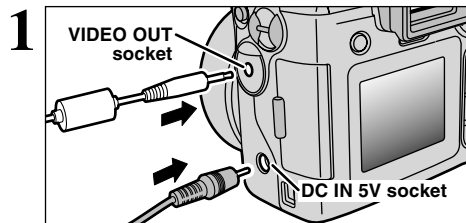

Switch off the camera and TV. Plug the Video cable (provided with the camera) into the "VIDEO OUT" (video output) socket.

- ⚠ If there is a power outlet available, connect the AC-5V AC Power Adapter.
- ⚠ Before plugging the video cable (included) into the VIDEO OUT socket, the LCD monitor and EVF display switches off.

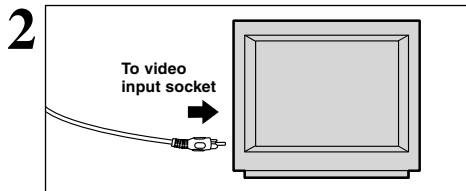

Plug the other end of the cable into the video input socket on the TV. Then switch the camera and TV on and play back images as you would normally.

- ⚠ Refer to the instructions provided with your TV for more information on video input for your TV.

7.1.3 Connecting to a computer

The "Camera Connection" section explains how to connect the camera to your computer using the included USB cable and describes the functions you can use once the camera and computer are connected.

If the power cuts out during data transmission, the data will not be transmitted correctly. Always use the AC power adapter when connecting the camera to a computer.

Refer to Section 6 the first time you connect the camera to your computer.
Do not connect the camera with the computer before installing all the software.



CD-ROM
(Software for FinePix SX)

DSC (Mass storage device) mode

This mode provides a simple way to read images from an **xD-Picture Card** and store images on to an **xD-Picture Card** (→P.98).

PC PC CAM (PC camera) mode

This function allows you to conduct videoconferencing sessions between PCs connected to the Internet.

- ⚠ Videoconferencing ("PictureHello") is not supported on Macintosh computers.
- ⚠ Connection is only possible with a FUJIFILM camera equipped with a "PC Camera" function.

7.1 CAMERA CONNECTION

For more information on using the software, refer to “How to use FinePixViewer” in the HELP menu which was installed from the CD-ROM.

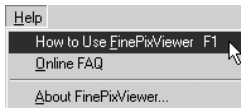

Switch between “↔” and “PC” in the camera’s SET-UP screen.

USE AT DSC MODE

1 Set a camera

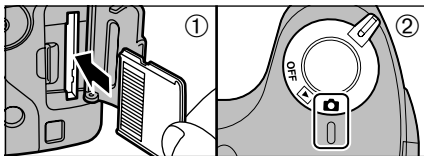

- 1 Insert an **xD-Picture Card** containing your shots into the camera.
- 2 Slide the Power switch to the side to turn the camera on.
- 3 Set the “USB MODE” setting in the “SET-UP” menu to “↔” (→P.77, 78).
- 4 Slide the Power switch to the side to turn the camera off.



- ⚠ Use the AC Power Adapter AC-5VH/AC-5VHS (sold separately) for the connection (→P.109). Loss of power during communication may damage the files on the **xD-Picture Card**.

2 Connect a camera to a computer

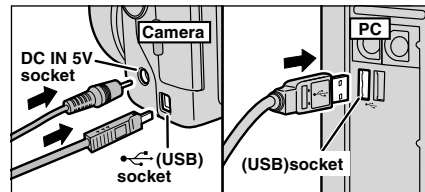

- 1 Switch your PC on.
- 2 Connect the camera to the PC using the USB cable (included).
- 3 Switch the camera on.

- ⚠ Take care to ensure that the USB cable (included) is connected the correct way around and that the plugs are pushed fully into the sockets.

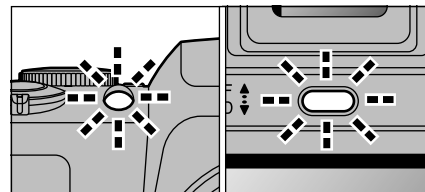

- When the camera and computer are exchanging data, the self-timer lamp blinks red and the indicator lamp blinks alternately green and orange.
- “↔ DSC” appears on the screen.
- Power Save and Auto Power Off are disabled during USB connection.

- ⚠ Before replacing the **xD-Picture Card**, always disconnect the camera from the PC using the procedure on P.102.
- ⚠ Do not disconnect the USB cable when the camera is communicating with the PC. See P.102 for information on the disconnection procedure.

7.1 CAMERA CONNECTION

3 Set a computer

Windows 98/98 SE/Me/2000 Professional/Macintosh

- The Windows CD-ROM may also be required during installation. In this event, switch CD-ROMs as directed by the on-screen instructions.
- FinePixViewer automatically starts up.



* Screen for Windows 98 SE

- A removable disk icon appears and you can use your PC to transfer files to and from the camera.



If the above operations do not occur, you do not have the required software programs or drivers installed on your PC. Complete the required PC setup procedures. Then reconnect the camera to your PC.

Windows XP

- ① The "Found New Hardware" help message appears in the bottom-right corner of your screen. This message will close when the settings are completed. No action is required.
 - This step is not required for subsequent connections.



- ② Specify the settings in the "AutoPlay" dialog box.

- **When FinePixViewer is included in the list of actions to perform**
Select "Viewing images using FinePixViewer" and then select the "Always do the selected action" checkbox. (This checkbox may not be shown in some cases.)
Click the [OK] button to launch FinePixViewer.
- **When FinePixViewer is not included in the list of actions to perform**
Select "Take no action" and then select the "Always do the selected action" checkbox. (This checkbox may not be shown in some cases.)
Click the [OK] button and launch FinePixViewer manually.

- ③ A new removable disk icon appears in the "My Computer" window.

◆ Regarding the Icons ◆

The next time you connect the camera, the removable disk drive icon and name change to the "FinePix" icon and name.

Proceed to "USING FinePixViewer" on P.104.

7.1 CAMERA CONNECTION

7.1.4 Disconnecting the camera

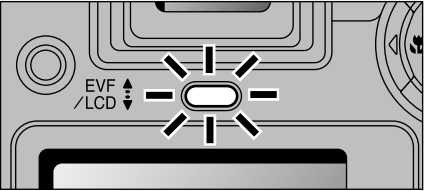
- 1** 
- Quit all applications (FinePixViewer etc.) that are using the camera.
 - Check that the indicator lamp is lit green (no data is being exchanged with the computer).
- For a DSC connection, proceed to step **2**.
For a PC CAMERA connection, proceed to step **3**.
- ⚠ Even when "Copying" is no longer displayed on the computer, the camera and the computer may still be exchanging data. Always check that the indicator lamp is lit green.

- 2** Perform the steps shown below before you switch the camera off. This procedure differs depending on the operating system software (or PC) you are using.

Windows 98/98 SE

No PC operation is needed.

Windows Me/2000 Professional/XP

- Right-click the removable disk icon in the "My Computer" window and select Eject. This step is only required in Windows Me.

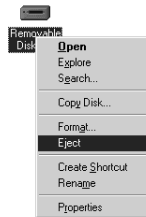

- Left-click the Eject icon in the taskbar and select "USB Disk".

* Screen for Windows Me



- The menu option shown below appears. Click on this option.

* Screen for Windows Me



- The "Safe To Remove Hardware" message box appears. Click the [OK] button or the close button.

Macintosh

Drag the "Removable drive" icon on the desktop to the Trash.

- ⚠ When you drag the icon to the Trash, "REMOVE OK" appears on the camera's LCD monitor.

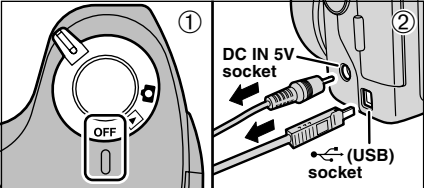

- 3** 
- Switch the camera off.
 - Unplug the USB cable (included) from the camera.

7.2 USING FinePixViewer

7.2.1 Mastering FinePixViewer

For all information on FinePixViewer functions, refer to “How to Use FinePixViewer” in the Help menu for details.

◆ Macintosh ◆

● To read “How to Use FinePixViewer”...

You must install Adobe Systems' Acrobat Reader. See P.89 for information on installing Acrobat Reader.

! For more information on using Acrobat Reader, refer to the Acrobat Reader “Help” menu.

● What is explained in “How to Use FinePixViewer”...

“How to Use FinePixViewer” covers a range of topics, including batch processing and ordering prints.

■ Example: Looking up slide shows

- ① Click “How to Use FinePixViewer” in the FinePixViewer Help menu.
- ② Click “Basic Operation” and then click “Basic Slide Show Operations” in the menu that appears.
- ③ The “Basic Slid Show Operations” information is displayed. Press the “<<<” key to view the previous page or the “>>>” key to view the next page.

7.2.2 Uninstalling the software

Only perform this operation when you no longer require the installed software or when the software was not installed correctly.

Windows

- ① Switch on your PC.
- ② Disconnect the camera (→P.102).
- ③ Quit all currently running applications.
- ④ Close all files.
- ⑤ Open the “My Computer” window, open the “Control Panel”, and double-click “Add/Remove Programs”.

- ⑥ The “Add/Remove Programs Properties” window appears. Select the software to be uninstalled (FinePixViewer or the driver) and then click the [Add/Remove] button.

<To remove FinePixViewer>

FinePixViewer Ver.4.1

<To remove the driver software>

FUJIFILM USB Driver



7.2 USING FinePixViewer

- ⑦ When the confirmation message appears, click the [OK] button. Check your selection carefully since the process cannot be cancelled once you click the [OK] button.



- ⑧ Automatic uninstallation begins.
When uninstallation ends, click the [OK] button.

Macintosh

- ⚠ Only perform this operation when you no longer require the installed software or when the software was not installed correctly.

Mac OS 9.0-9.2

■ Uninstalling Mass Storage Driver and PC Camera Driver

- ① Check that the camera is not connected to your Macintosh.
- ② Open the "Extensions" folder in the System folder, and then drag all the files that begin with "USB04CB..." to the Trash.
- ③ Restart your Macintosh.
- ④ Select "Empty Trash" in the "Special" menu.

■ Uninstalling Exif Launcher, FinePixViewer and DP Editor

- ① After you have quit Exif Launcher in "Exif Launcher Settings" in the FinePixViewer "Settings" menu, move the Exif Launcher file from the "Startup Items" folder in the System folder to the Trash. Then select "Empty Trash" in the "Special" menu.
- ② After you have exited FinePixViewer and DP Editor drag the installed FinePixViewer folder to the Trash. Then click "Empty Trash" in the "Special" menu.

Mac OS X

■ Uninstalling FinePixViewer

Quit FinePixViewer and DP Editor. Then drag the installed FinePixViewer folder to the Trash and select "Empty Trash" in the "Special" menu.

System Expansion Options

- By using the FinePix S3000 together with other optional FUJIFILM products, your system can be expanded to fill a wide range of uses.

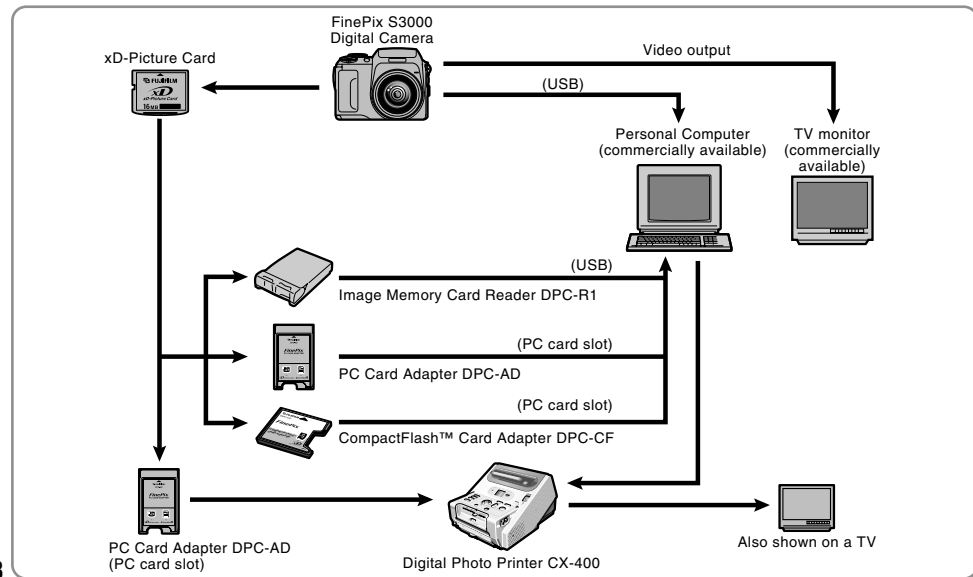

Accessories Guide

- The accessories (sold separately) can make taking pictures with the FinePix S3000 even easier. For information on how to attach and use the accessories, refer to the instructions provided with the accessory used.

Visit the FUJIFILM web site for the latest information on camera accessories.
<http://home.fujifilm.com/products/digital/index.html>

● xD-Picture Card

These are separately available **xD-Picture Cards**.

Use the following **xD-Picture Card**:

DPC-16 (16 MB)/DPC-32 (32 MB)/DPC-64 (64 MB)/DPC-128 (128 MB)/
DPC-256 (256 MB)/DPC-512 (512 MB)



● AC Power Adapter AC-5VH/AC-5VHS

Use the AC-5VH/AC-5VHS when you want to take pictures or play back images for long periods or when the FinePix S3000 is connected to a personal computer.

* The shape of the AC power adapter, the plug and socket outlet depend on the country.

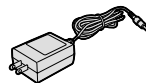

● Fujifilm Rechargeable Battery 2HR-3UF

The 2HR-3UF includes 2 pieces of high-capacity AA-size Nickel-Metal Hydride (Ni-MH) batteries.

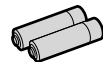

● Fujifilm Battery charger with Battery BK-NH/BK-NH2 (With Euro type or UK type plug)

The BK-NH/BK-NH2 includes the quick battery charger BCH-NH/BCH-NH2 and 2 Ni-MH batteries.

The BCH-NH/BCH-NH2 can charge 2 Ni-MH batteries in approximately 120 minutes. Up to 4 Ni-MH batteries can be charged simultaneously.

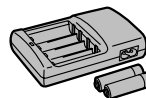

● SC-FX304

This is a special case made of polyester that protects the camera against soiling, dust and minor impacts when it is being carried.

● Image Memory Card Reader DPC-R1

The DPC-R1 provides a quick and easy way to transfer images back and forth between your PC and an image memory card (**xD-Picture Card** and SmartMedia). The DPC-R1 uses the USB interface for high-speed file transfer.

- Compatible with Windows 98/98 SE, Windows Me, Windows 2000 Professional, Windows XP or iMac, Mac OS 8.6 to 9.2.2, Mac OS X (10.1.2 to 10.2.2) and models that support USB as standard.
- Compatible with **xD-Picture Card** of 16 MB to 512 MB, and SmartMedia of 3.3V, 4 MB to 128 MB.

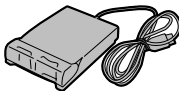

● PC Card Adapter DPC-AD

The PC Card Adapter allows the **xD-Picture Card** and SmartMedia to be used as a PC Card Standard ATA-compliant (PCMCIA 2.1) PC card (Type II).

- Compatible with **xD-Picture Card** of 16 MB to 512 MB, and SmartMedia of 3.3V, 2 MB to 128 MB.



● CompactFlash™ Card Adapter DPC-CF

Loading an **xD-Picture Card** into this adapter allows you to use the card as a CompactFlash card (Type I).

- Windows 95/98/98 SE/Me/2000 Professional/XP
- Mac OS 8.6 to 9.2/X (10.1.2 to 10.1.5)



▶ Be sure to read this information in conjunction with “Safety Notes” (⇒P.126), to ensure that you use your camera correctly.

■ Places to Avoid

Do not store or use the camera in the following types of locations:

- In the rain or in very humid, dirty or dusty places.
- In direct sunlight or in places subject to extreme temperature rises, such as in a closed car in summer.
- Extremely cold places.
- Places subject to strong vibration.
- Places affected by smoke or steam.
- Places subject to strong magnetic fields (such as near motors, transformers or magnets).
- In contact with chemicals such as pesticides or next to rubber or vinyl products for long periods of time.

■ Notes on Immersion in Water or Sand

The FinePix S3000 is particularly adversely affected by water and sand. When you are at the beach or close to water, ensure that the camera is not exposed to water or sand. Take care also not to place the camera on a wet surface. Water or sand inside the camera can cause faults that may be irreparable.

■ Notes on Condensation

If the camera is carried suddenly from a cold location into a warm place, water droplets (condensation) may form on the inside of the camera or on the lens. When this occurs, switch the camera off and wait an hour before using the camera. Condensation may also form on the **xD-Picture**

Card. In this event, remove the **xD-Picture Card** and wait a short time before using it again.

■ When the Camera is Unused for Long Periods

If you do not intend to use the camera for a long period of time, remove the batteries and the **xD-Picture Card** before storing the camera.

■ Cleaning Your Camera

- Use a blower brush to remove dust from the lens, LCD monitor screen or viewfinder as these surfaces, and then wipe lightly with a soft, dry cloth. If any soiling remains, apply a small amount of lens cleaning liquid to a piece of FUJIFILM lens cleaning paper and wipe gently.
- Do not scratch hard objects against the lens, LCD monitor screen or viewfinder as these surfaces are easily damaged.
- Clean the body of the camera with a soft, dry cloth. Do not use volatile substances such as thinners, benzine or insecticide, as these may react with camera body and cause deformation or remove the coating.

■ Using the Camera Overseas

When travelling overseas, do not place your camera in the check-in baggage. Baggage handling at airports may subject baggage to violent shocks, and the camera may be damaged internally even when no external damage is visible.

Notes on the Power Supply

Applicable Batteries

- AA-size alkaline, Ni-MH (nickel-metal hydride) can be used with this camera. Do not use AA-size manganese or nickel-cadmium(Ni-Cd) batteries in your FinePix S3000 because the heat generated by the batteries could damage the camera or cause malfunctions.
- The operating lives of alkaline batteries vary between brands and the life of batteries you purchase may be shorter than the alkaline batteries provided with the camera.

Notes on the Batteries

Incorrect use of the batteries could cause them to leak, become hot, ignite or burst. Always observe the precautions given below.

- Do not heat the batteries or throw them into a fire.
- Do not carry or store the batteries with metal objects such as necklaces or hairpins that could come into contact with the metal positive ⊕ and negative ⊖ poles of the battery.
- Do not expose the batteries to fresh or sea water, and take particular care to keep the terminals dry.
- Do not attempt to deform, disassemble or modify the batteries.
- Do not attempt to peel off or cut the battery casing.
- Do not drop, strike or otherwise subject the batteries to strong impacts.

- Do not use the batteries that are leaking, deformed, discolored or exhibit any other obvious abnormality.
- Do not store the batteries in very warm or moist locations.
- Keep the batteries out of reach of infant and young children.
- When loading the batteries into the camera, ensure that the battery polarity (⊕ and ⊖) is as indicated on the camera.
- Do not use new batteries together with used batteries. In the case of rechargeable batteries, do not use charged and discharged batteries together. Do not use batteries of different types or brands together.
- If you do not intend to use the camera for a long period of time, remove the batteries from the camera. (Note that if the camera is left with the batteries removed, the time and date settings are cleared.)
- The batteries may feel warm immediately after being used. Before removing the batteries, switch the camera off and wait until the batteries cool down.
- When replacing the batteries, always fit 4 new batteries. Here, “new batteries” refers to either recently purchased unused alkaline batteries, or Ni-MH (nickel-metal hydride) batteries that have recently been fully recharged together.
- In cold locations (at temperatures of +10°C/+50°F or below), battery performance deteriorates and the time for which they can be used shortens markedly. This is particularly true of alkaline batteries. In cold conditions, put the batteries in your pocket or a similar place to warm them before loading them into the camera. If you use a body warmer to warm the batteries, ensure that they are not in direct contact with the warmer.

- Soil (such as fingerprints) on the battery terminals can markedly reduce the number of available shots. Carefully wipe the battery terminals clean with a soft dry cloth before loading the batteries.

- ⚠ If any liquid at all leaks from the batteries, wipe the battery compartment thoroughly and then load new batteries.
- ⚠ If any battery fluid comes into contact with your hands or clothing, flush the area thoroughly with water. Note that battery fluid can cause loss of eyesight if it gets into your eyes. If this occurs, do not rub your eyes. Flush the fluid out with clean water and contact your physician for treatment.

Disposing of Batteries

When disposing of batteries, do so in accordance with your local waste disposal regulations.

Notes on Small Rechargeable Batteries (Ni-MH batteries)

- Always use the special battery charger to charge AA-size Ni-MH batteries. Charge the batteries as described in the instructions provided with the battery charger.
- Do not use the battery charger to charge batteries other than those specified for use with the charger.
- Note that the batteries may feel warm immediately after being charged.
- Ni-MH batteries are not charged at shipment. Be sure to charge the batteries before using them.
- The camera mechanism is such that it draws a minute amount of current even when the camera is switched off.

Take particular care not to leave Ni-MH batteries in the camera for a long period of time as they can become excessively discharged and may no longer be usable even when charged.

- Ni-MH batteries self-discharge even when not used. Always charge Ni-MH batteries before using them. If the time for which a battery provides power shortens markedly when it has been correctly charged, this indicates that the battery has reached the end of its effective life and should be replaced.
- Soiling (fingerprints, etc.) on the terminals of Ni-MH batteries can greatly reduce the number of available shots. When this occurs, clean the terminals carefully with a soft dry cloth. Then use up the remaining charge in the batteries and recharge them.
- Newly purchased batteries or batteries that have been left unused for an extended period may not be fully charged. (This is indicated by the immediate display of the battery low warning or a low number of available shots.) This is a normal characteristic of the batteries and does not indicate a fault. Repeatedly charging and using the batteries 3 or 4 times will restore them to a normal condition.
- If you repeatedly charge a Ni-MH battery before it is fully discharged, it will suffer from the “memory effect”*, causing the battery low warning to appear while there is still ample charge remaining in the battery. To restore the batteries to their normal condition, use up all the charge in the batteries before recharging them.

Notes on the Power Supply

* Memory effect: A phenomenon affecting the battery characteristics such that the apparent battery capacity decreases.

Notes on Using the AC Power Adapter

Always use the AC-5VH/AC-5VHS AC Power Adapter with the FinePix S3000 Camera.

The use of an AC power adapter other than the AC-5VH/AC-5VHS could result in damage to your FinePix S3000 Digital Camera.

- This AC power adapter is designed exclusively for indoor use.
- Plug the connection cord plug securely into the DC input terminal of the FUJIFILM Digital camera.
- Turn off the power switch of the FUJIFILM Digital camera before disconnecting the connection cord from the FUJIFILM Digital camera's DC input terminal. To disconnect, take hold of the plug and pull it out (do not disconnect it by pulling on the cord).
- Do not use this AC power adapter with any device except the specified device.
- During use, this AC power adapter will become hot to touch, but this is normal.
- Do not disassemble the AC power adapter. Doing so could be dangerous.
- Do not use this device in a place with high temperature and high humidity.
- Do not drop or subject this device to strong shocks.

- This device may emit a humming noise, but this is normal.
- If used near a radio, this device may cause static, so play the radio in a distant place.

Notes on the xD-Picture Card™

■ Image Memory Card

- This Image Memory Card is a new image recording media (**xD-Picture Card**) developed for digital cameras. The Image Memory Card consists of a semiconductor memory (NAND-type flash memory) to record digital image data. The recording process is electrically performed and enables erasure of existing image data as well as re-recording of new image data.
- When using a new Memory Card, or a Memory Card that has been initialized by a PC, be sure to initialize (format/initialize) the card with your digital camera before using it.

■ Protecting Your Data

- Data may be lost or destroyed in the following situations. Please note that FUJIFILM assumes no responsibility for data that is lost or destroyed.
 1. Removal of the memory card or turning the power off while the memory card is being accessed (i.e., during record, erase, initialization, and playback operations).
 2. Improper handling and use of the memory card by the user or third party.
- We recommend saving your important data to another media (i.e., MO disk, CD-R, hard disk, etc.).

■ Notes on Handling xD-Picture Card

- Keep **xD-Picture Cards** out of the reach of small children. When storing **xD-Picture Cards**, ensure that they are kept in a location out of the reach of small children to prevent a card being accidentally swallowed. An **xD-Picture Card** could cause suffocation if accidentally swallowed. If a child swallows an **xD-Picture Card**, seek medical advice immediately.
- Make sure that the memory card is straight when you insert into the camera etc.
- The memory card is a precision electronic instrument. Do not apply pressure or shock, and avoid bending.
- Do not use the memory card in a hot, humid, or corrosive environment.
- If the contact area on the card is soiled (dust, fingerprints, etc.), wipe it clean with a soft, dry cloth.
- Clean the memory card with a soft dry piece of cloth when dirty.
- **xD-Picture Cards** should be kept in their special cases or carrying cases when being stored or carried around.
- The memory card can be used reliably for a long period of time, but will eventually lose its ability to store and play back image data. At this point, replace with a new memory card.
- Never remove the **xD-Picture Card** or switch the

camera off during data recording, during data erasing (xD-Picture Card formatting) or during frame advance when images are being played back. These actions could result in damage to the xD-Picture Card.

- The use of xD-Picture Cards is recommended with the FinePix S3000.

The camera quality cannot be guaranteed when cards other than those manufactured by FUJIFILM are used.

- The xD-Picture Card may feel warm when it is removed from the camera after extended periods of picture taking or image viewing. This is normal and does not indicate a fault.
- Do not affix labels to the xD-Picture Card. This could result in the label peeling off and causing a fault when the card is inserted or removed.

■ Notes on Using xD-Picture Card with a PC

- If you intend to take photos using an xD-Picture Card that has been used on a PC, format the xD-Picture Card on your camera.
- When you format an xD-Picture Card in the camera and then shoot and record images, a directory (folder) is automatically created. Image data is then recorded in this directory.
- Do not change or delete the directory (folder) names or file names on the xD-Picture Card from your PC as this will make it impossible to use the xD-Picture









Card in your camera.

- Always use the camera to erase image data on an xD-Picture Card.
- To edit image data, copy the image data to the PC's hard disk and then edit the copied data.
- Do not copy files other than those that will be used by the camera.

■ Specifications

Type	Image memory card for digital cameras (xD-Picture Card)
Memory type	NAND-type flash memory
Conditions for use	Temperature: 0°C to +40°C (+32°F to +104°F) Humidity: 80% max. (no condensation)
Dimensions	25 mm × 20 mm × 2.2 mm (0.98 in. × 0.79 in. × 0.09 in.) (W × H × D)

► The table below lists the warnings that are displayed on the screen

Warning Displayed	Explanation	Remedy
 (Lit red)  (Blinking red)	The batteries in the camera are fully depleted or very low on charge.	Replace the batteries or have new batteries ready.
	There is a strong likelihood of camera shake because the shutter speed is slow.	Use flash photography. However, a tripod should be used for some scenes and modes.
	Outside the AE continuous range.	The shot can be taken, but the exposure will not be correct.
	The AF (auto focus) cannot work effectively.	<ul style="list-style-type: none"> • If the image is too dark, take the picture at a distance of around 2 m (6.6 ft.) from the subject. • Use AF lock to take the picture.
	No xD-Picture Card is loaded.	Insert an xD-Picture Card in the correct direction.
	<ul style="list-style-type: none"> • The xD-Picture Card is not formatted. • The xD-Picture Card contact area is soiled. 	<ul style="list-style-type: none"> • Format the xD-Picture Card. • Wipe the contact area on the xD-Picture Card with a soft dry cloth. It may be necessary to format the xD-Picture Card. If the error message is still displayed, replace the xD-Picture Card. • Contact your FUJIFILM dealer.
	<ul style="list-style-type: none"> • The xD-Picture Card contact area is soiled. • The xD-Picture Card is damaged. • The xD-Picture Card format is incorrect. 	<ul style="list-style-type: none"> • Wipe the contact area on the xD-Picture Card with a soft dry cloth. It may be necessary to format the xD-Picture Card. If the error message is still displayed, replace the xD-Picture Card. • Contact your FUJIFILM dealer.
	The xD-Picture Card is fully recorded.	Erase some images or use an xD-Picture Card that has ample free space.

Warning Displays

► The table below lists the warnings that are displayed on the screen

Warning Displayed	Explanation	Remedy
READ ERROR	<ul style="list-style-type: none"> The file played back was not recorded correctly. The xD-Picture Card contact area (gold-colored area) is soiled. Camera fault. You attempted to play a movie that was not recorded on this camera. 	<ul style="list-style-type: none"> Images cannot be played back. Wipe the contact area on the xD-Picture Card with a soft dry cloth. It may be necessary to format the xD-Picture Card. If the error message is still displayed, replace the xD-Picture Card. Contact your FUJIFILM dealer. Movies cannot be played back.
FILE NO. FULL	The frame number has reached 999–9999.	Take the shot using a formatted xD-Picture Card .
WRITE ERROR	<ul style="list-style-type: none"> The data could not be recorded due to an xD-Picture Card error or a connection error between the xD-Picture Card and camera. The photographed image cannot be recorded as it is too large to fit in the available space on the xD-Picture Card. 	<ul style="list-style-type: none"> Re-insert the xD-Picture Card or switch the camera off and then on again. Use a new xD-Picture Card.
PROTECTED FRAME	A protected file was encountered.	Protected files cannot be erased. Remove the protection.

Warning Displayed	Explanation	Remedy
DPOF FILE ERROR	Prints were specified for more than 1000 frames in the DPOF frame settings.	The maximum number of frames for which prints can be specified on the same xD-Picture Card is 999. Copy the images for which you want to order prints onto another xD-Picture Card and then specify the DPOF settings.
FOCUS ERROR ZOOM ERROR	Camera malfunction or fault.	<ul style="list-style-type: none"> Switch the camera on again, taking care not to touch the lens. Switch the camera off and on again.
❌ CAN NOT SET DPOF	Movie selected in the DPOF settings.	You cannot use DPOF to order prints of movies.

Troubleshooting

► If you think the camera is faulty, check the following once more.

Troubleshooting	Possible causes	Solutions
No power.	<ul style="list-style-type: none"> The batteries are exhausted. The AC power adapter plug has come out of the power outlet. The batteries are loaded the wrong way round. 	<ul style="list-style-type: none"> Load new fully charged batteries. Plug the adapter back in. Load the batteries in the correct direction.
Power cuts out during operation.	The batteries are exhausted.	Load new fully charged batteries.
Batteries run out quickly.	<ul style="list-style-type: none"> Camera is being used in extremely cold conditions. The terminals are soiled. The batteries have reached the end of their operating lives. 	<ul style="list-style-type: none"> Put the batteries in your pocket or another warm place to heat them and then load them into the camera just before you take a picture. Wipe the battery terminals with a clean, dry cloth. Load new fully charged batteries.
No photograph is taken when the shutter button is pressed.	<ul style="list-style-type: none"> No xD-Picture Card is loaded. The xD-Picture Card is fully recorded. The xD-Picture Card is write-protected. The xD-Picture Card is not formatted. The xD-Picture Card contact area (gold-colored area) is soiled. The xD-Picture Card is damaged. The Power Save function has switched the camera off. The batteries are exhausted. 	<ul style="list-style-type: none"> Load an xD-Picture Card. Insert a new xD-Picture Card or erase some unwanted frames. Remove the write-protection. Format the xD-Picture Card. Wipe the xD-Picture Card contact area (gold-colored area) with a clean dry cloth. Load a new xD-Picture Card. Switch the camera on. Load new fully charged batteries.

Troubleshooting	Possible causes	Solutions
Can't use the flash to take pictures.	<ul style="list-style-type: none"> The Shutter button was pressed while the flash was charging. The batteries are exhausted. The Suppressed Flash mode is selected. 	<ul style="list-style-type: none"> Wait until charging is completed before pressing the Shutter button. Load new fully charged batteries. Set the flash mode to Auto, Red-eye Reduction or Forced Flash (The flash cannot be used in some modes).
Can only select "Suppressed Flash" flash mode.	Continuous shooting is selected.	Set continuous shooting to OFF.
The photographed image is dark even though I used the flash.	<ul style="list-style-type: none"> The subject is too far away. Your finger was covering the flash/flash control sensor. 	<ul style="list-style-type: none"> Move to within the effective flash range before taking the shot. Hold the camera correctly.
The playback image is faded when I used the flash to take a picture.	<ul style="list-style-type: none"> There is dust on the flash control sensor. 	<ul style="list-style-type: none"> Use an applicator such as a cotton swab to clean the flash control sensor.
The image is blurred.	<ul style="list-style-type: none"> The lens is dirty. You photographed scenery with Macro mode selected. You took a close-up shot without selecting Macro mode. You are shooting a subject that is not suited to autofocus. 	<ul style="list-style-type: none"> Clean the lens. Cancel Macro mode. Select Macro mode. Use AF/AE lock to take the shot.
There is speckling on the image.	The shot was taken with a slow shutter speed (long exposure) in a high-temperature environment.	This is a characteristic of CCDs and does not indicate a camera fault.

▶ If you think the camera is faulty, check the following once more.

Troubleshooting	Possible causes	Solutions
Frame erase does not erase the frame. The ERASE ALL function does not erase all the frames.	Some frames may be protected.	Unprotect frames using the camera on which the protection was first applied.
Can't format the xD-Picture Card .	The xD-Picture Card contact area is soiled.	Wipe the xD-Picture Card contact area with a clean dry cloth.
When the camera is connected to a personal computer (PC), the shot image appears on the camera's LCD monitor.	<ul style="list-style-type: none"> The FinePix S3000 USB cable (included) is not properly connected to the computer or camera. The PC is not switched on. 	<ul style="list-style-type: none"> Set up the camera and the FinePix S3000 USB cable (included) correctly. Switch the PC on.
Nothing happens when I use the Mode switch.	<ul style="list-style-type: none"> Camera malfunction. The batteries exhausted. 	<ul style="list-style-type: none"> Briefly remove the batteries or disconnect the AC power adapter. Then reload the batteries or reconnect the AC power adapter and try again. Replace the batteries.
Screens are not displayed in English.	A language other than English is selected in the "LANGUAGE" setting in SET-UP. (➡P.78)	Select "ENGLISH" in the "LANGUAGE" setting in SET-UP.
The camera no longer works correctly.	The camera has suffered an unforeseen problem.	Briefly remove the batteries or disconnect the AC power adapter. Then reload the batteries or reconnect the AC power adapter and try again.

System

- **Model:** Digital Camera FinePix S3000
- **Effective pixels:** 3.2 million pixels
- **CCD**
1/2.7-inch square pixel CCD with RGB Filter
Number of total pixels: 3.34 million pixels
- **Storage media**
xD-Picture Card (16/32/64/128/256/512 MB)
- **File format**
Still image: JPEG (Exif Ver.2.2), DPOF-compatible
Movie: AVI format, Motion JPEG
* Design rule for Camera File system compliant
- **Number of recorded pixels**
2048 × 1536 pixels/1600 × 1200 pixels/1280 × 960 pixels/
640 × 480 pixels
- **Lens:** Fujinon 6× optical zoom lens F2.8-F3
- **Focus length:** f=6 mm-36 mm
(equivalent to 38 mm-228 mm on a 35 mm camera)
- **Focal range**
Normal: Approx. 80 cm/2.6 ft. to infinity
Macro: Approx. 10 cm-80 cm/3.9 in.-2.6 ft.
- **Shutter speed**
Auto/SP:1/4 sec. to 1/1500 sec. SP(Night scene mode only):3 sec. to 1/250 sec.Manual(A.priority):1/2 sec. to 1/1500 sec.
- **Aperture:** F2.8/F4.8/F8.2 (Wide-angle) F3/F5.2/F8.7 (Telephoto) automatically selected
- **Sensitivity**
At flash off:Equivalent to ISO 100
At flash on:Equivalent to ISO 100-200(automatically selected)
- **Exposure control**
64 zones TTL metering, Program AE
(exposure compensation available in Manual mode)

- **White balance**
Auto (7 positions selectable in Manual mode)
- **Viewfinder:** 0.33 inches 110,000 pixels electronic viewfinder
- **LCD monitor**
1.8-inches, 62,000 pixels amorphous silicon TFT
- **Flash (Auto flash using flash control sensor)**
Effective range: Wide Approx. 0.3 m-3.5 m (1.0 ft.-11.5 ft.)
Tele Approx. 0.8 m-3.5 m (2.6 ft.-11.5 ft.)
Flash modes: Auto, Red-Eye Reduction, Forced Flash, Suppressed Flash, Slow Synchro, Red-Eye Reduction + Slow Synchro
(when the pop-up flash is stowed: Suppressed Flash)
- **Self-Timer:** Approx 10 sec. timer clock
- **Video output:** NTSC/PAL selectable

Input/Output Terminals

- **Video output socket**
2.5mm dia. jack
- **(USB) socket**
For file transfer to a computer
- **DC Input**
Socket for specified AC Power adapter AC-5VH/AC-5VHS (sold separately)

Power Supply and Others

- **Power supply**
Use one of the following:
 - 4AA-size alkaline batteries
 - 4AA-size Ni-MH (Nickel-Metal Hydride) batteries (sold separately)
 - AC Power Adapter AC-5VH/AC-5VHS (sold separately)

Specifications

● Guide to the number of available frames for battery operation

Battery type	Using LCD monitor	Using EVF
Alkaline batteries	Approx. 350 frames*	Approx. 400 frames*
Ni-MH batteries 2100 mAh	Approx. 400 frames*	Approx. 450 frames*

* With fully charged battery

This indicates the number of available frames shot consecutively at room temperature with a flash use rate of 50%. Note that these figures may vary depending on the ambient temperature and the amount of charge in the battery. The number of available shots or available shooting time will be lower in cold conditions.

● Conditions for use

Temperature: 0°C to +40°C (+32°F to +104°F); 80% humidity or less (no condensation)

● Camera dimensions (W/H/D)

99.7 mm × 77.3 mm × 69.3 mm/3.9 in. × 3.0 in. × 2.7 in.
(not including accessories and attachments)

● Camera mass (weight):

Approx. 283 g/10.0 oz.
(not including accessories, batteries or xD-Picture Card)

■ Standard number of available frames/recording time per xD-Picture Card

The number of available frames, recording time or file size varies slightly depending on the subjects photographed. Note also that the divergence between standard number of available frames and the actual number of available frames is greater for xD-Picture Cards with higher capacities.

Quality mode	3M 3M	2M 2M	1M 1M	0.3M 0.3M	Movie 820	Movie 160
Number of recorded pixels	2048 × 1536	1600 × 1200	1280 × 960	640 × 480	320 × 240	160 × 120
Image Data Size	780 KB	630 KB	470 KB	130 KB	—	—
DPC-16 (16 MB)	19	25	33	122	Approx. 98 sec.	Approx. 5.6 min.
DPC-32 (32 MB)	40	50	68	247	Approx. 199 sec.	Approx. 11.3 min.
DPC-64 (64 MB)	81	101	137	497	Approx. 6.6 min.	Approx. 22.7 min.
DPC-128 (128 MB)	162	204	275	997	Approx. 13.3 min.	Approx. 45.5 min.
DPC-256 (256 MB)	325	409	550	1997	Approx. 26.7 min.	Approx. 91.2 min.
DPC-512 (512 MB)	651	818	1101	3993	Approx. 53.5 min.	Approx. 182.5 min.

● **Weight for photography:** Approx. 411 g/14.5 oz.
(including batteries, xD-Picture Card, lens cap and strap)

● **Accessories:** See P.7

● **Optional Accessories:** See P.109, 110

* These specifications are subject to change without notice. FUJIFILM shall not be held liable for damages resulting from errors in this Owner's Manual.

* The LCD monitor and viewfinder on your digital camera are manufactured using advanced high-precision technology. Even so, small bright points and anomalous colors (particularly around text) may appear on the monitor and viewfinder. These are normal display characteristics and do not indicate a fault with the monitor and viewfinder. This phenomenon will not appear on the recorded image.

* The operation error may be caused in a digital camera by the strong radio interference (i. e. electric fields, static electricity, line noise, etc.).

* Due to the nature of the lens, the edges of photographed images may appear distorted. This is normal and does not indicate a fault.

Explanation of Terms

DPOF: Digital Print Order Format

DPOF is a format used for recording information on a storage media (image memory card, etc.) that allows you to specify which of the frames shot using a digital camera are printed and how many prints are made of each image.

EV:

A number that denotes exposure. The EV is determined by the brightness of the subject and sensitivity (speed) of the film or CCD. The number is larger for bright subjects and smaller for dark subjects. As the brightness of the subject changes, a digital camera maintains the amount of light hitting the CCD at a constant level by adjusting the aperture and shutter speed. When the amount of light striking the CCD doubles, the EV increases by 1. Likewise, when the light is halved, the EV decreases by 1.

Frame rate (fps):

The frame rate is a unit used to indicate the number of images (frames) played back per second. This camera shoots movie files at 10 consecutive frames per second, a rate that is expressed as 10 fps. By comparison, TV images are played at 30 fps.

JPEG:

Joint Photographics Experts Group

A file format used for compressing and saving color images. The compression ratio can be selected, but the higher the compression ratio, the poorer the quality of the expanded image.

Motion JPEG:

A type of AVI (Audio Video Interleave) file format that handles images and sound as a single file. Images in the file are recorded in JPEG format. Motion JPEG can be played back by QuickTime 3.0 or later.

PC Card:

A generic term for cards that meet the PC Card Standard.

PC Card Standard:

A standard for PC cards determined by the PCMCIA.

PCMCIA:

Personal Computer Memory Card International Association (US).

White Balance:

Whatever the kind of the light, the human eye adapts to it so that a white object still looks white. On the other hand, devices such as digital cameras see a white subject as white by first adjusting the color balance to suit the color of the ambient light around the subject. This adjustment is called matching the white balance. A function that automatically matches the white balance is called an **Automatic White Balance function**.

Exif Print



Exif Print Format is a newly revised digital camera file format that contains a variety of shooting information for optimal printing.

Safety Notes



- To ensure that you use your FinePix S3000 camera correctly, read these Safety Notes and your Owner's Manual carefully beforehand.
- After reading these Safety Notes, store them in a safe place.





About the Icons





The icons shown below are used in this document to indicate the severity of the injury or damage that can result if the information indicated by the icon is ignored and the product is used incorrectly as a result.







	WARNING This icon indicates that death or serious injury can result if the information is ignored.
	CAUTION This icon indicates that personal injury or material damage can result if the information is ignored.

The icons shown below are used to indicate the nature of the information which is to be observed.







-  Triangular icons notify the user of information requiring attention ("Important").
-  Circular icons with a diagonal bar notify the user that the action indicated is prohibited ("Prohibited").
-  Filled circles with an exclamation mark notify the user of an action that must be performed ("Required").





 WARNING	
<p>When a fault arises, switch the camera off and then remove the batteries and disconnect the AC power adapter.</p> <p>Continued use of the camera when it is emitting smoke, is emitting any unusual odor, or is in any other abnormal state can cause a fire or electric shock.</p> <p>● Contact your FUJIFILM dealer.</p>	 Unplug from power socket.
<p>Do not allow water or foreign objects to enter the camera.</p> <p>If water or foreign objects get inside the camera, switch the camera off, remove the battery and disconnect and unplug the AC power adapter.</p> <p>Continued use of the camera can cause a fire or electric shock.</p> <p>● Contact your FUJIFILM dealer.</p>	
<p>Do not place the camera on an unstable surface.</p> <p>This can cause the camera to fall or tip over and cause injury.</p>	
<p>Do not use the camera in the bathroom or shower.</p> <p>This can cause a fire or electric shock.</p>	 Do not use in the bathroom or shower.

 WARNING	
<p>Never attempt to modify or disassemble the camera. (Never open the casing.)</p> <p>Do not use the camera when it has been dropped or the casing is damaged.</p> <p>This can cause a fire or electric shock.</p> <p>● Contact your FUJIFILM dealer.</p>	 Do not disassemble.
<p>Never attempt to take pictures while in motion.</p> <p>Do not use the camera while you are walking or operating a moving car or other vehicle.</p> <p>This can result in you falling down or being involved in a traffic accident.</p>	
<p>Do not heat, modify or attempt to disassemble the batteries.</p> <p>Do not drop or subject the batteries to impacts.</p> <p>Do not attempt to recharge lithium or alkaline batteries.</p> <p>Do not store the batteries with metallic products.</p> <p>Any of these actions can cause the batteries to burst or leak and cause fire or injury as a result.</p>	
<p>Do not touch any metal parts of the camera during a thunderstorm.</p> <p>This can cause an electric shock due to induced current from the lightning discharge.</p>	

 WARNING	
<p>Do not use the batteries except as specified.</p> <p>Load the batteries with the poles positioned as indicated by the ⊕ and ⊖ marks.</p>	
<p>Use only the batteries or AC power adapter specified for use with this camera.</p> <p>The use of other power sources can cause a fire.</p>	
<p>If the battery leaks and fluid gets into your eyes or comes into contact with your skin or clothing, this can cause injury or loss of eyesight. Immediately flush the affected area thoroughly with clean water and seek medical treatment.</p>	
<p>When discarding or storing batteries, cover the battery terminals with insulation tape.</p> <p>● Contact with other metallic objects or batteries could cause the batteries to ignite or burst.</p>	
<p>Keep xD-Picture Cards out of the reach of small children.</p> <p>Because xD-Picture Cards are small, they can be accidentally swallowed by small children. Be sure to store xD-Picture Cards out of the reach of small children. If a child accidentally swallows an xD-Picture Card, seek medical advice immediately.</p>	

Safety Notes

 CAUTION	
Keep out of the reach of small children. This product could cause injury in the hands of a child.	
Do not use this camera in locations severely affected by oil fumes, steam, humidity or dust. This can cause a fire or electric shock.	
Do not leave this camera in places subject to extremely high temperatures. Do not leave the camera in locations such as a sealed vehicle or in direct sunlight. This can cause a fire.	
Do not place heavy objects on the camera. This can cause the heavy object to tip over or fall and cause injury.	
Do not move the camera while the AC power adapter is still connected. This can damage the power cord or cables and cause a fire or electric shock.	
Do not cover or wrap the camera or the AC power adapter in a cloth or quilt. This can cause heat to build up and distort the casing or cause a fire.	

 CAUTION	
Remove the batteries and disconnect the AC power adapter when you are cleaning the camera or if you intend to leave the camera unused for a long period. Failure to do so can cause a fire or electric shock.	
Using a flash too close to a person's eyes may temporarily affect the eyesight. Take particular care when photographing infants and young children.	
Request regular internal testing and cleaning for your camera. Build-up of dust in your camera can cause a fire or electric shock. ● Contact your FUJIFILM dealer to request internal cleaning every 2 years.	
When an xD-Picture Card is removed, the card may fly completely out of the slot. Use your finger to stop the card flying out before removing the card. If an xD-Picture Card is allowed to fly out, it could hit someone and cause injury.	

EC Declaration of Conformity

We
Name : Fuji Photo Film (Europe) G.m.b.H.
Address : Heesenstrasse 31
40549 Dusseldorf, Germany

declare that the product
Product Name : FUJIFILM DIGITAL CAMERA FinePix S3000
Manufacturer's Name : Fuji Photo Film Co., Ltd.
Manufacturer's Address : 26-30, Nishiazabu 2-chome, Minato-ku,
Tokyo 106-8620, Japan

is in conformity with the following Standards

Safety : EN60065
EMC : EN55022 : 1998 Classe B
EN55024 : 1998
EN61000-3-2 : 1995 + A1:1998 + A2:1998

following the provision of the EMC Directive (89/336/EEC, 92/31/EEC and 93/68/EEC) and Low Voltage Directive (73/23/EEC).

CE

Dusseldorf, Germany

September 1, 2003

Place

Date

Signature/Managing Director



Bij dit produkt zijn batterijen geleverd. Wanneer deze leeg zijn, moet u ze niet weggooien maar inleveren als KCA

NOTICE

BEFORE OPENING THE PACKAGE OF CD-ROM PROVIDED BY FUJI PHOTO FILM CO., LTD., PLEASE READ THIS END USER LICENSE AGREEMENT CAREFULLY. ONLY IF YOU DO AGREE TO THIS AGREEMENT, YOU WILL BE ABLE TO USE THE SOFTWARE RECORDED ON THE CD-ROM. BY OPENING THE PACKAGE, YOU ACCEPT AND AGREE TO BE BOUND BY THIS AGREEMENT.

End User License Agreement

This End User License Agreement ("Agreement") is an agreement between Fuji Photo Film Co., Ltd. ("FUJIFILM") and you, which sets forth the terms and conditions of the license granted for you to use the software provided by FUJIFILM.

The CD-ROM contains third party software. In case a separate agreement is provided by a third party supplier for its software, the provisions of such separate agreement shall apply to the use of such third party software, prevailing over those of this Agreement.

1. Definitions.

- (a) "Media" means the CD-ROM titled "Software for FinePix SX" which is provided to you together with this Agreement.
- (b) "Software" means the software which is recorded on Media.
- (c) "Documentation" means the operation manuals of Software and other related written materials which are provided to you together with Media.
- (d) "Product" means Media (including Software) and Documentation collectively.

2. Use of Software.

FUJIFILM grants to you a nontransferable, nonexclusive license:

- (a) to install one copy of Software onto one computer in binary machine executable form;
- (b) to use Software on the computer onto which Software is installed; and
- (c) to make one backup copy of Software.

3. Restrictions.

- 3.1 You shall not distribute, rent, lease or otherwise transfer all or any part of Software, Media or Documentation to any third party without FUJIFILM's prior written consent. You also shall not sublicense, assign or otherwise transfer all or any part of the rights granted to you by FUJIFILM under this Agreement without FUJIFILM's prior written consent.
- 3.2 Except as expressly granted by FUJIFILM hereunder, you shall not copy or reproduce all or any part of Software or Documentation.
- 3.3 You shall not modify, adapt or translate Software or Documentation. You also shall not alter or remove copyright and other proprietary notices that appear on or in Software or Documentation.
- 3.4 You shall not, or shall not have any third party, reverse-engineer, decompile, or disassemble Software.

4. Ownership.

All copyrights and other proprietary rights to Software and Documentation are owned and retained by FUJIFILM or the third party suppliers as indicated on or in Software or Documentation. Nothing contained herein shall be construed, expressly or implicitly, as transferring or granting any right, license, or title to you other than those explicitly granted under this Agreement.

5. Limited Warranty.

FUJIFILM warrants to you that Media is free from any defect in material and workmanship under normal use for ninety (90) days from the date of your receipt of Media. Should Media not meet the foregoing warranty, FUJIFILM shall replace such defective Media with other Media bearing no defect. FUJIFILM's entire liability and your sole and exclusive remedy with regard to any defect in Media shall be expressly limited to such FUJIFILM's replacement of Media as provided herein.

6. DISCLAIMER OF WARRANTY.

EXCEPT AS PROVIDED IN SECTION 5 HEREIN, FUJIFILM PROVIDES PRODUCT "AS IS" AND WITHOUT WARRANTIES OF ANY KIND, EXPRESS OR IMPLIED. FUJIFILM SHALL MAKE NO WARRANTY, EXPRESS, IMPLIED OR STATUTORY, AS TO ANY OTHER MATTERS, INCLUDING, BUT NOT LIMITED TO NON-INFRINGEMENT OF ANY COPYRIGHT, PATENT, TRADE SECRET, OR ANY OTHER PROPRIETARY RIGHTS OF ANY THIRD PARTY, MERCHANTABILITY, OR FITNESS FOR ANY PARTICULAR PURPOSE.

7. LIMITATION OF LIABILITY.

IN NO EVENT SHALL FUJIFILM HAVE ANY LIABILITY FOR ANY GENERAL, SPECIAL, DIRECT, INDIRECT, CONSEQUENTIAL, INCIDENTAL, OR OTHER DAMAGES (INCLUDING DAMAGES FOR LOSS OF PROFITS OR LOST SAVINGS) INCURRED FROM THE USE OF OR INABILITY TO USE PRODUCT EVEN IF FUJIFILM HAS BEEN ADVISED OF THE POSSIBILITY OF SUCH DAMAGES.

8. No export.

You acknowledge that neither Software nor any part thereof, will be transferred, or exported to any country or used in any manner in violation of any export control laws and regulations to which Software is subject.

9. Termination.

In case you breach any of the terms and conditions hereof, FUJIFILM may immediately terminate this Agreement without any notice.

10. Term.

This Agreement is effective until the date when you cease to use Software, unless earlier terminated in accordance with Section 9 hereof.

11. Obligation upon termination.

Upon termination or expiration of this Agreement, you shall, at your own responsibility and expense, delete or destroy immediately all Software (including its copies), Media and Documentation.

12. Governing Law.

This Agreement shall be governed by and construed in accordance with laws of Japan.



FUJI PHOTO FILM CO., LTD.

26-30, Nishiazabu 2-chome, Minato-ku, Tokyo 106-8620, Japan

<http://home.fujifilm.com/products/digital/>

Printed in Japan

Printed on recycled paper.

FGS-305108-FG